

**ALIGNMENT, LEVELING AND  
DEPLOYMENT CONSTRAINTS  
FOR APOLLO 15 LUNAR  
SCIENTIFIC EXPERIMENTS**

## CONTENTS

	<u>Page Number</u>
ALSEP Array "C" Deployment Arrangement	1
Central Station	
Crew Deployment Description	2
Leveling and Alignment	3
Central Station Antenna	
Crew Deployment Description	4
Leveling, Alignment, and Pointing	5
Radioisotope Thermoelectric Generator (RTG)	6
Crew Deployment Description	
Passive Seismic Experiment (PSE)	
Crew Deployment Description	7
Leveling and Alignment	8
Solar Wind Spectrometer (SWS)	
Crew Deployment Description	9
Leveling and Alignment	10
Lunar Surface Magnetometer	
Crew Deployment Description	11
Leveling and Alignment	12

CONTENTS

	<u>Page Number</u>
Suprathermal Ion Detector Experiment (SIDE)	
Crew Deployment Description	13
Leveling and Alignment	14
Heat Flow Experiment (HFE)	
Crew Deployment Description	15-16
Leveling and Alignment	17
Laser Ranging Retro-Reflector (LR <sup>3</sup> )	
Crew Deployment Description	18
Leveling and Alignment	19

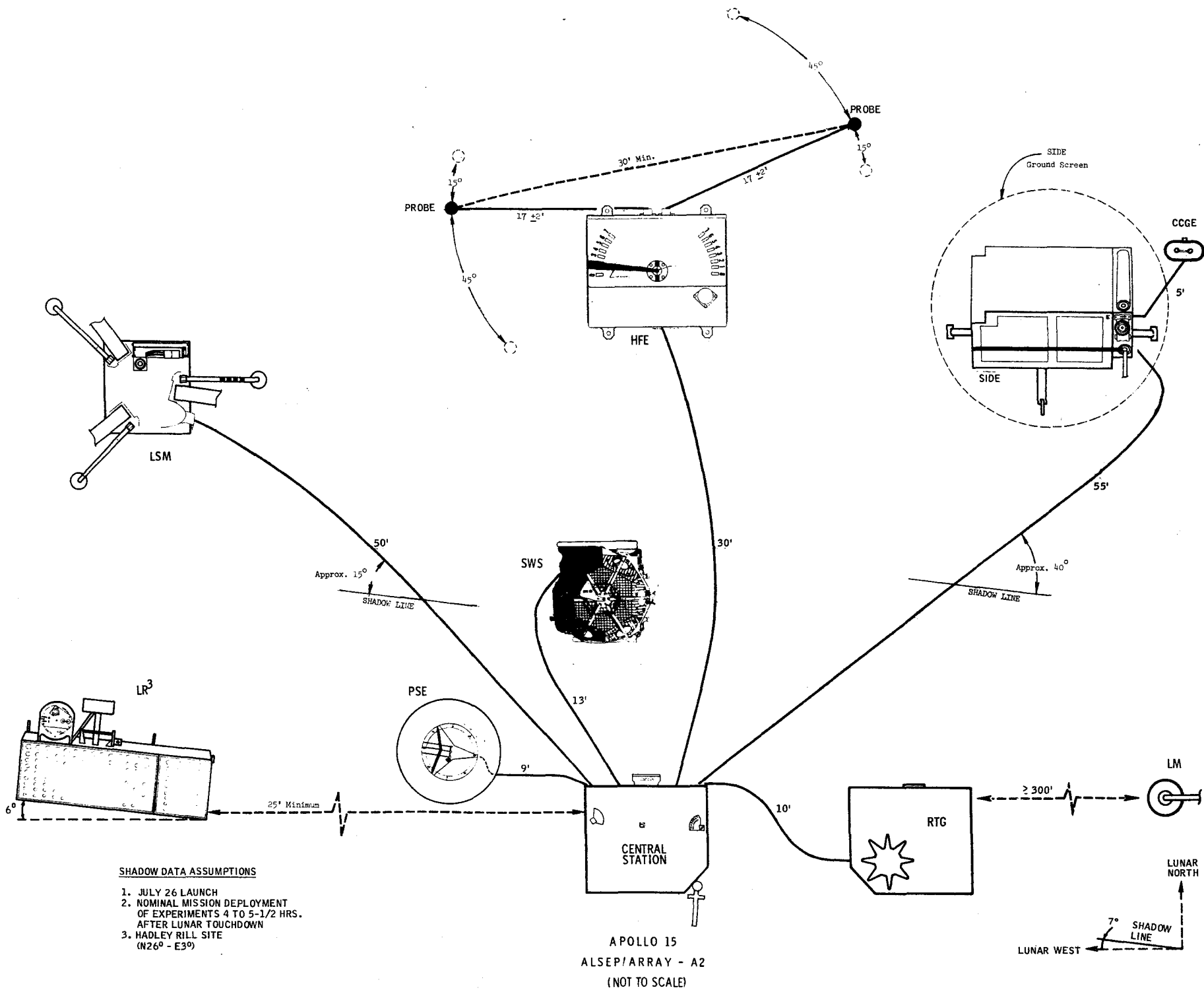

CENTRAL STATION DEPLOYMENT CONSTRAINTS

PARAMETER	CONSTRAINTS
Site Selection	<p>Minimum of 300 feet West of LM. At minimum distance, the LM ascent engine blast should not harm ALSEP. Must not be deployed in shadow of LM. Astronaut will choose approximately horizontal site to provide stable base for antenna. Must avoid craters and slopes which would degrade thermal control of unit.</p>
Leveling	<p>While sun shield is still down in stowed position, astronaut will level unit within 5 degrees so that bubble is within the outer case circle of bubble level. Bubble should be free from case circle to be within 5 degrees.</p>
Alignment	<p>Astronaut must align unit within <math>\pm 5</math> degrees of East-West line using partial compass rose to assure thermal control capability of Central Station. Central Station radiator faces North. Curtained sides of Central Station face East and West.</p>
Thermal Control	<p>Central Station radiator requires clear field-of-view for good thermal control. Central Station must not be shaded from sun more than absolutely necessary prior to deployment. Design of ALSEP allows deployment when sun angle is from 5 to 45 degrees.</p>

# CENTRAL STATION LEVELING & ALIGNMENT

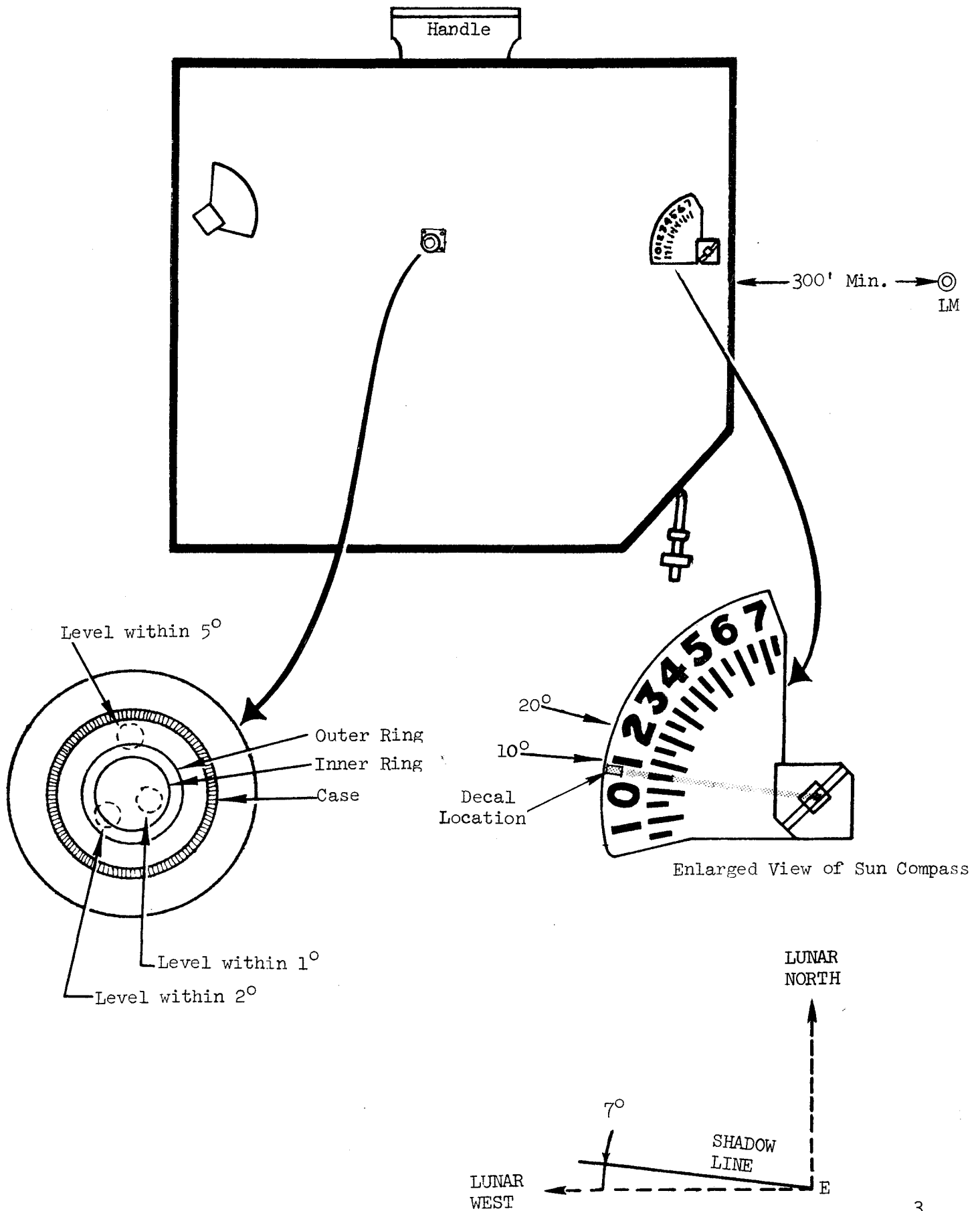

CENTRAL STATION ANTENNA DEPLOYMENT CONSTRAINTS

PARAMETER	CONSTRAINTS
Antenna Level	Within $0.5^{\circ}$ of vertical as determined by bubble level. Bubble should be free from case circle to be within $0.5$ degrees.
Antenna Alignment	$\pm 0.5^{\circ}$ of sun line as determined by sun dial. When shadow coincides with shadow reference line alignment is within $\pm 0.5$ .
Antenna Azimuth	Astronaut will set azimuth dial to value shown on his cuff check list to assure adequate signal strength for life of ALSEP.
Antenna Elevation	Astronaut will set elevation dial to value shown on his cuff check list to assure adequate signal strength for life of ALSEP.

# CENTRAL STATION ANTENNA LEVELING AND ALIGNMENT

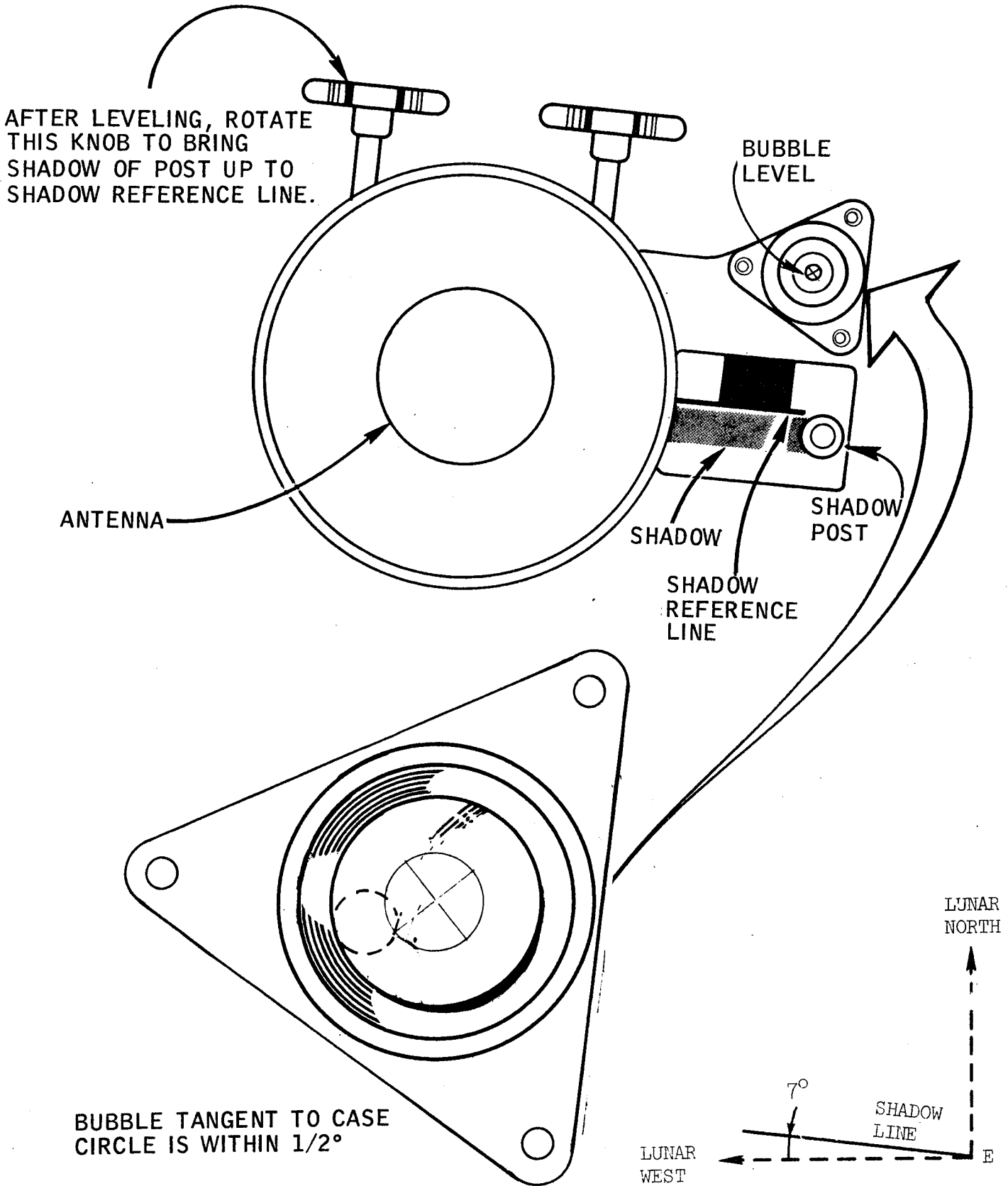



RTG DEPLOYMENT CONSTRAINTS

PARAMETER	CONSTRAINTS
Separation between RTG and Central Station	9 to 12 feet, limited by 13-foot cable with about 1 foot of slack. Hot RTG should be away from Central Station to avoid contact with astronaut, and to provide maximum heat radiation into free space.
RTG Orientation from Central Station	East of Central Station $+ 20^{\circ}$ , visually determined by astronaut, to minimize thermal load on Central Station.
RTG Deployment Site	Horizontal site. Pallet should be horizontal $+ 10^{\circ}$ , visually determined by astronaut. No mechanical provisions for astronaut to level RTG. Astronaut will avoid craters and slopes which impede dissipation of heat from RTG.
RTG Alignment	No constraint, but astronaut will align so that RTG cable exit points toward Central Station.
Interrelation	Astronaut will read ammeter on shorting switch box (to confirm a value greater than zero) and then connect RTG to Central Station. After connection is made, the shorting switch is actuated and ammeter goes to zero.

PSE DEPLOYMENT CONSTRAINTS

PARAMETER	CONSTRAINTS
PSE - to - Central Station Separation	8 to 9 feet West of Central Station limited by 10-foot cable with 1-foot slack.
PSE - to - RTG Separation	15-foot minimum separation from RTG is necessary to avoid thermal input.
PSE Orientation from Central Station	North-West of Central Station, on opposite side from the RTG, visually determined by astronaut.
PSE Deployment Site	Approximately level spot, free from loose material. PSE must be no less than 10 feet from other units to minimize pickup of stray vibrations by PSE. Pack surface to prevent sinking.
PSE Alignment	Before removing the PSE girdle, the astronaut must align the PSE within $\pm 20$ degrees of the sun line by pointing the arrow on the girdle the sun. Fine alignment will be reported after removing girdle and spreading thermal shroud. Astronaut will read and report, to the nearest degree, where the shadow of the gnomon falls on the compass rose. PI must know final alignment within $\pm 5$ degrees with reference to sun line.
PSE Leveling	Must be coarse leveled by astronaut within 5 degrees of vertical. (5 degrees is the limit of the automatic, fine-leveling gimbal system.)

# PASSIVE SEISMIC EXPERIMENT (PSE) LEVELING AND ALIGNMENT

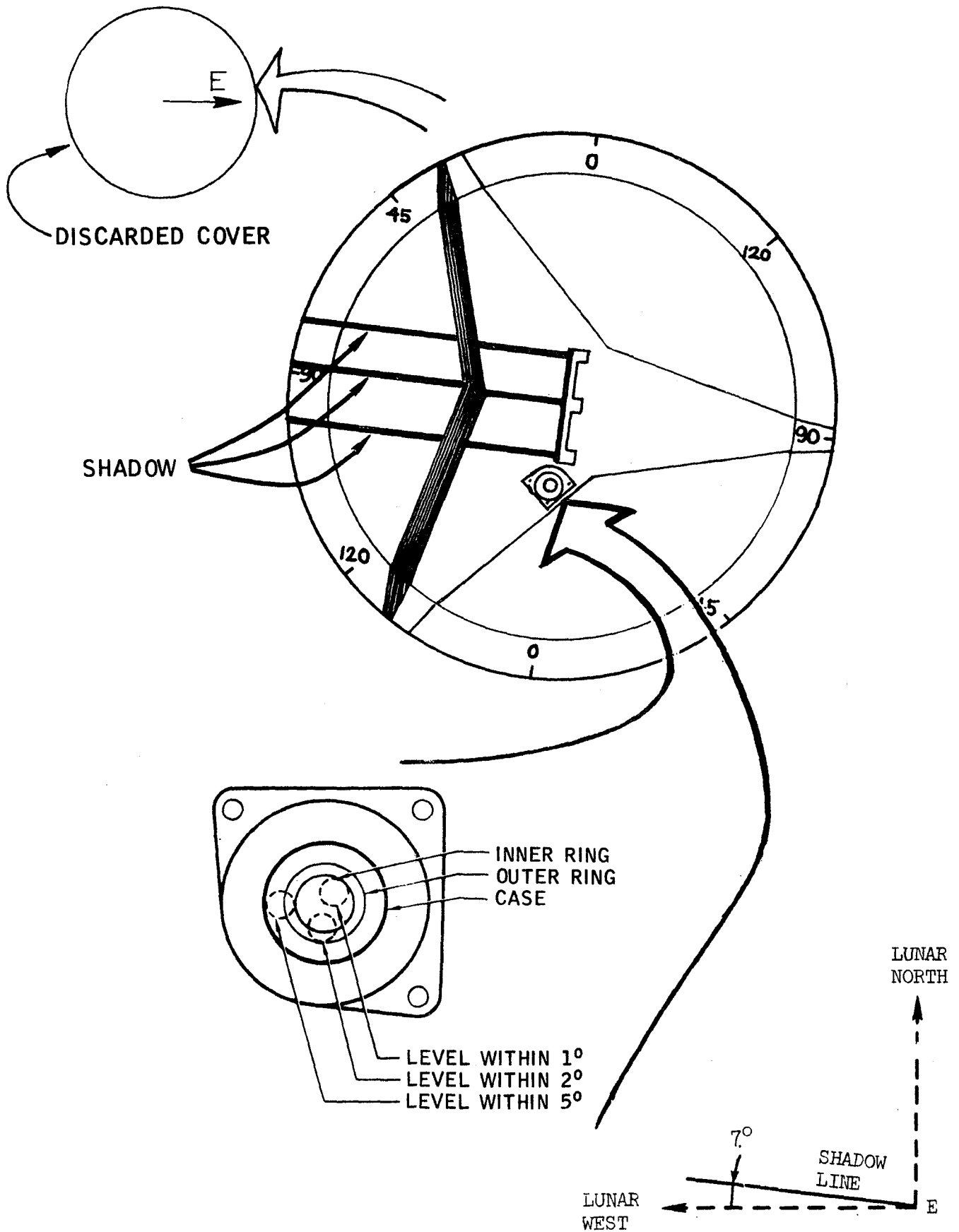

SOLAR WIND SPECTROMETER (SWS)  
DEPLOYMENT CONSTRAINTS

PARAMETER	CONSTRAINTS
SWS Site Selection	Deploy SWS 12 to 15 feet north of Central Station. Orient SWS so that louvered side (radiator) points approximately due North.
Leveling	Level the SWS to within 5° of horizontal about N-S axis. SWS should be placed in an approximately horizontal spot to avoid thermal perturbations. Due to A-frame construction, there is a pendulum effect about E-W axis; SWS should swing freely. No fine leveling about N-S axis is necessary since N-S orientation is determined from sun sensor TM data. Note that sun shade has swung to its up position in contact with the sensor mounting plate. If not, raise it.
Alignment	Align SWS by rotating about a vertical axis so that the shadow cast by the north edge of the sensor assembly cupola runs parallel to the edge of the sun shield.
Fine Alignment	Fine align the SWS box by touching the box with the handling tool near the bottom on the south side to see whether it swings freely on its E-W pivot. If not free, move the leg assemblies farther apart so that the instrument swings freely and recheck alignment.
Remarks	Louvered side (radiator) should be away from RTG and Central Station due to thermal control requirements.

# SOLAR WIND SPECTROMETER LEVELING AND ALIGNMENT

Note: Spectrometer to be rotated and implaced assuring free N-S Pendulous action, so that shadow cast by gnomon is parallel with E-W edge of sunshield

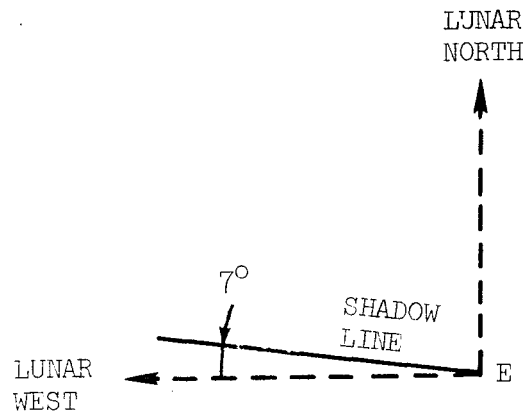
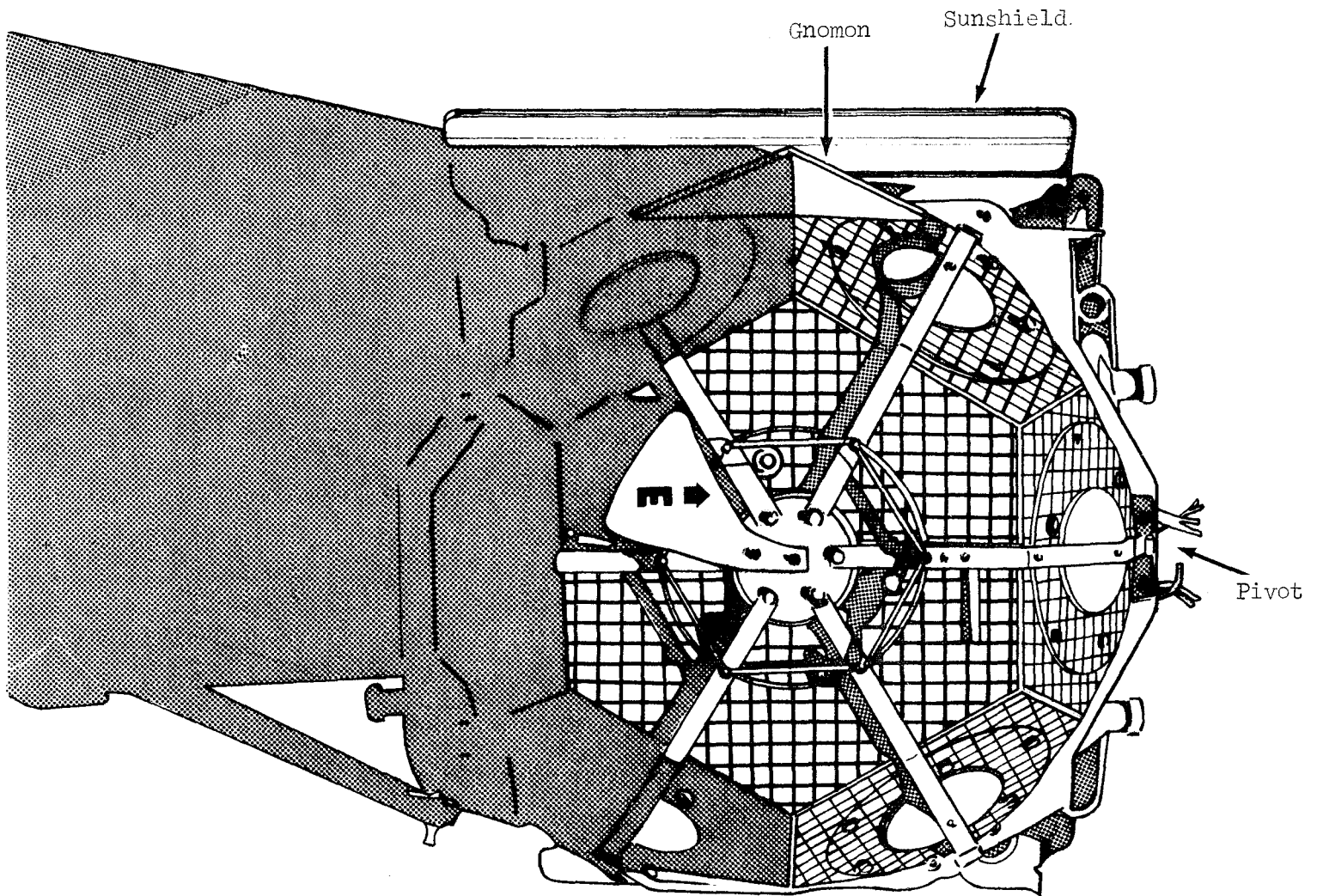

LUNAR SURFACE MAGNETROMETER (LSM)  
DEPLOYMENT CONSTRAINTS

PARAMETER	CONSTRAINTS
Site Selection	Deploy LSM 40 to 48 feet Northwest of the Central Station limited by 50-foot cable. This separation is required to minimize EMI effects on LSM sensors.
Alignment	Align the LSM to within $\pm 3^\circ$ of East-West sun line. Astronaut should read the shadowgraph within $\pm 1^\circ$ . Alignment is critical because thermal control is critical and exact alignment is required to interpret LSM scientific data.
Leveling	<p>LSM should be placed in an approximately level spot, free from loose material. Level the LSM to within <math>\pm 3^\circ</math> of vertical using bubble level.</p> <p><u>Note:</u> LSM must be a minimum of 80' from the SIDE/CCGE which contains a strong magnet.</p>

# LUNAR SURFACE MAGNETOMETER LEVELING AND ALIGNMENT

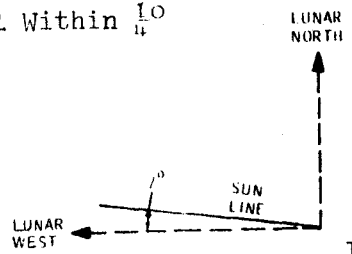
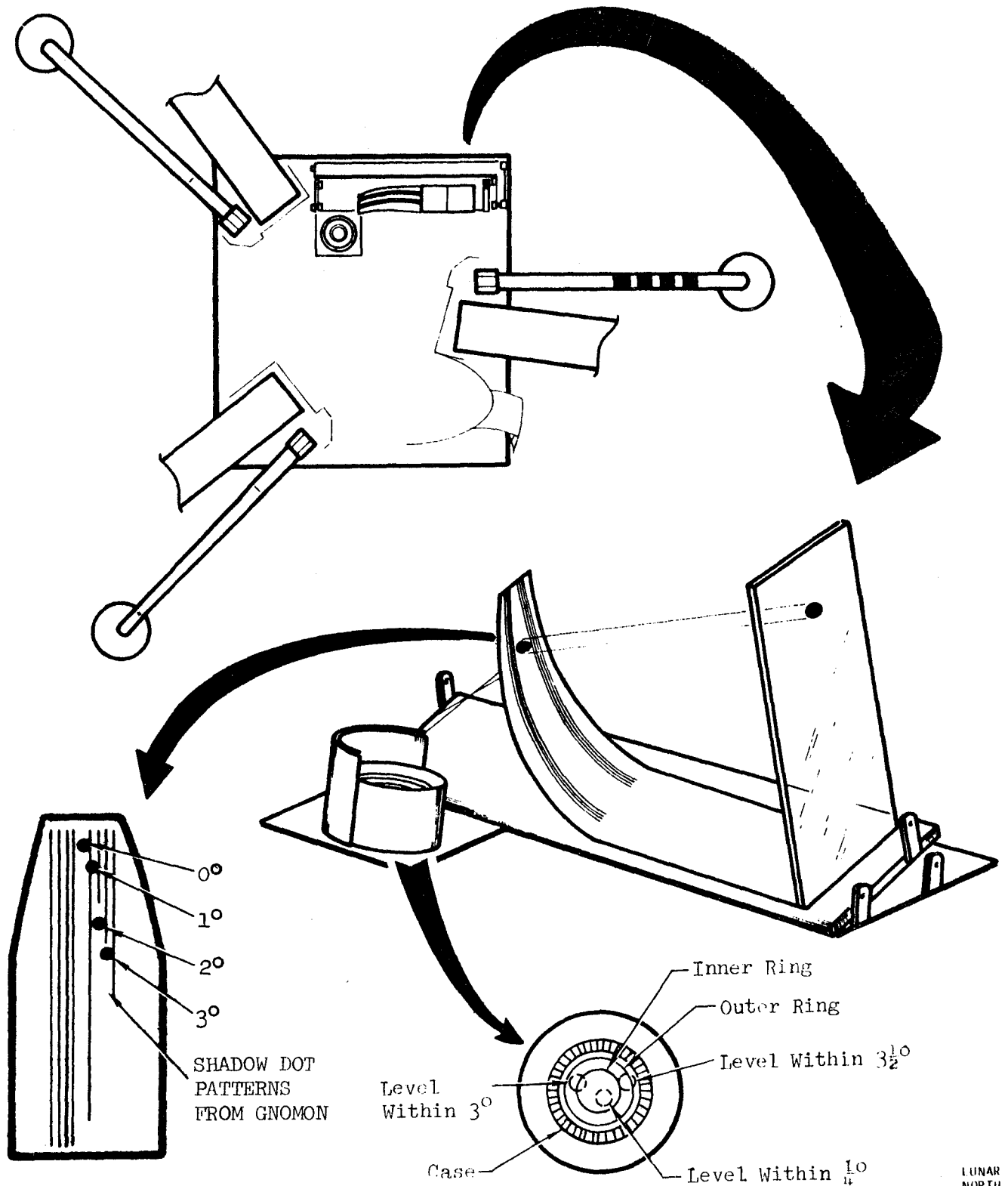

SIDE/CCGE DEPLOYMENT CONSTRAINTS

PARAMETER	CONSTRAINTS
SIDE - Central Station Separation	50 to 60 feet, limited by 60-foot cable.
SIDE Orientation from Central Station	Northeast of Central Station, visually determined by astronaut.
Site Selection	Smooth, as determined by astronaut, to allow emplacement of ground screen and instruments.
Leveling	Astronaut will utilize bubble level to level the SIDE. Must be within 5° of vertical. Bubble should be free from case circle to be within 5 degrees.
SIDE Alignment	Astronaut will rough align unit utilizing arrow on top of unit. Arrow, marked "E", points toward sun. Then he will fine align unit within +5° of sun line by visually determining that the shadow cast by the UHT is parallel to the long sides of unit. This requirement is dictated by detector orientation inside of unit. Experience indicates that when the shadow from the UHT looks parallel to units long sides the 10 degree alignment tolerance will be met.
CCGE Alignment	It is desirable that the orifice be +20° of North-South line, oriented so it has a clear field of view, away from all other subsystems and the LM. The arrow on the unit is to point North. The orifice should be pointed approximately horizontally across the lunar surface.
CCGE - SIDE Separation	CCGE must be clear of the SIDE ground screen.  <u>Note:</u> CCGE includes a strong magnet which would affect LSM if separation is not at least 80'.



SUPRATHERMAL ION DETECTOR EXPERIMENT (SIDE)  
LEVELING AND ALIGNMENT

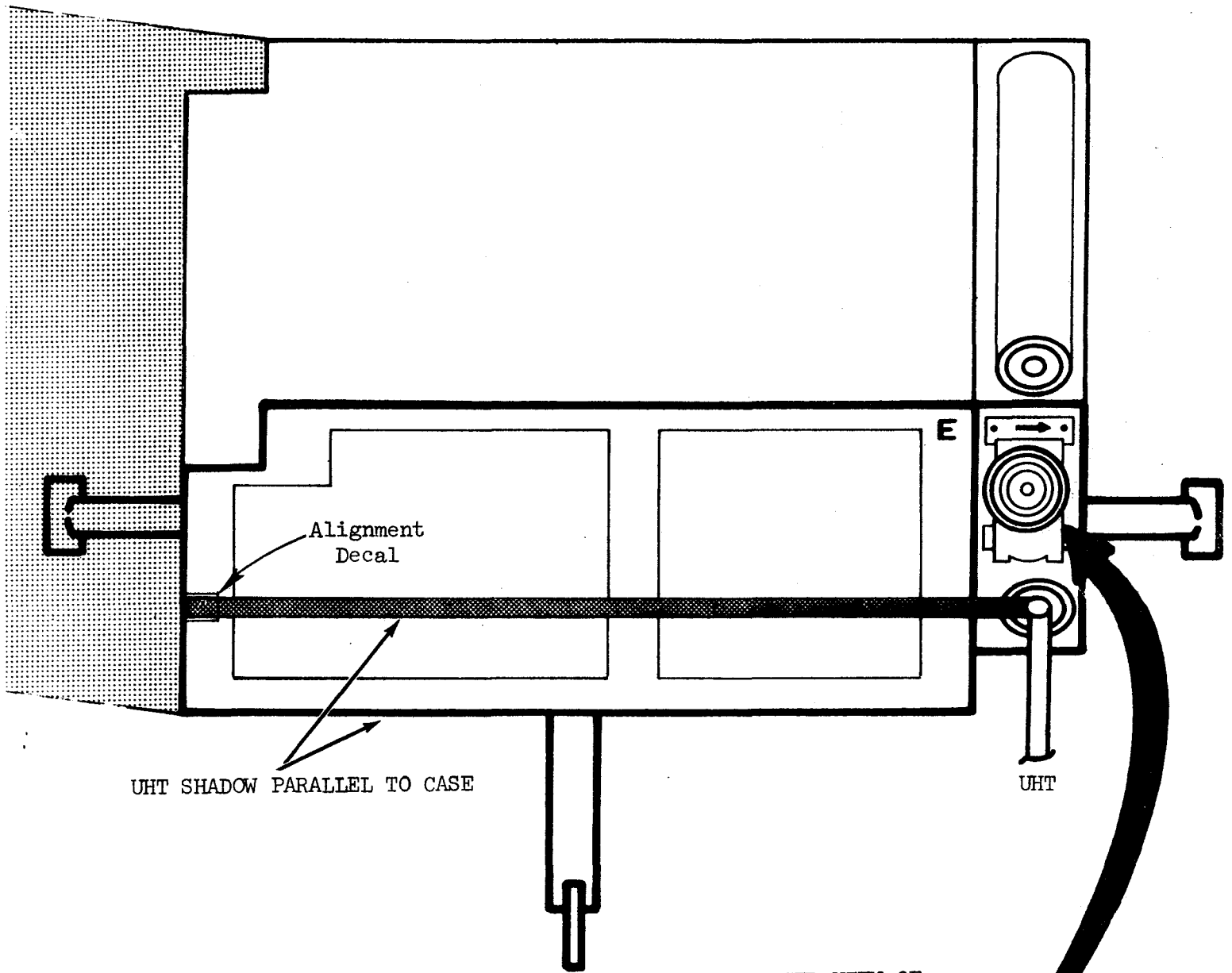

UHT SHADOW PARALLEL TO CASE

Alignment Decal

UHT

ENLARGED VIEW OF  
5 DEGREE BUBBLE

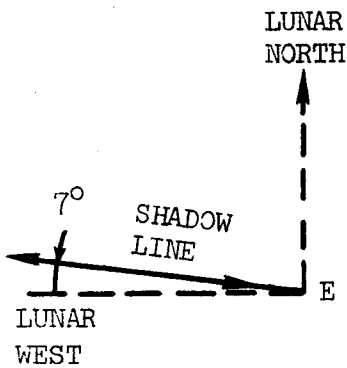

WITHIN 5° WHEN TANGENT  
TO CASE CIRCLE

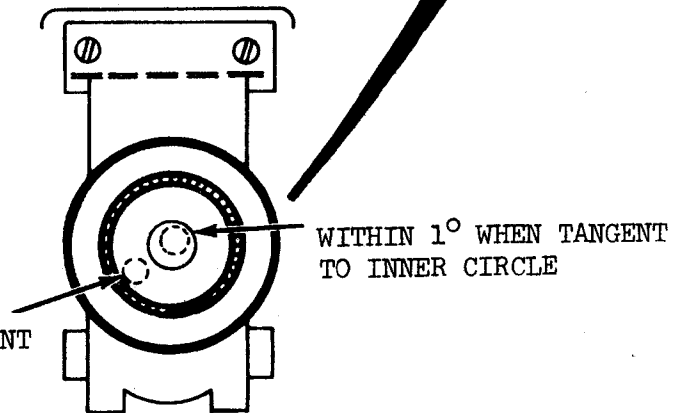

HEAT FLOW EXPERIMENT (HFE)  
DEPLOYMENT CONSTRAINTS

PARAMETER	CONSTRAINTS
Site Selection	<p>Deploy the HFE Electronics Package 25 to 30 feet north of the Central Station.. HFE Electronics Package should be placed in an approximately level area, removed from any surface irregularities or rocks that may obscure the field-of-view of the HFE sunshield reflector.</p>
Alignment	<p>Align the HFE Electronics Package to within <math>+ 5^{\circ}</math> of the plane of the ecliptic or lunar equator. This is accomplished by rotating package until shadow cast by UHT covers alignment decal. Radiator must face away from equator. Deploy the Probes 15 to 19 feet from the <del>15</del><sup>25</sup> Electronics Package maintaining <del>10</del> foot minimum separation between Probes and RTG.</p> <p>When the HFE bore holes have been drilled with the ALSD, the probes should be inserted and should be vertical within <math>+ 15^{\circ}</math> as determined visually by the astronaut.</p>
Leveling	<p>Level the HFE Electronics Package to within <math>5^{\circ}</math> of vertical using bubble level. Bubble should be free from case circle to be within 5 degrees.</p>
Remarks	<p>If feasible, the HFE Probes should be placed at least 200 feet from fresh craters with surrounding strewn fields of stones.</p> <p>The HFE Probes should be at least 5 diameters from large isolated blocks (boulders) greater than 2 feet across exposed at the surface.</p> <p>Try to avoid topographic features greater than two feet in diameter, such as craters or hummocks that have a relief greater than 10 to 1, (slopes of <math>10^{\circ}</math>).</p>

HEAT FLOW EXPERIMENT (HFE)  
DEPLOYMENT CONSTRAINTS  
(Continued)

PARAMETER	CONSTRAINTS
	<p>On the scale of 100's of feet topographic highs should be avoided and depressions preferred to assure thickest possible regolith.</p> <p>The HFE should be at least 10 feet from all other experiments and at least 20 feet from the PSE and at least 25 feet from the RTG.</p>

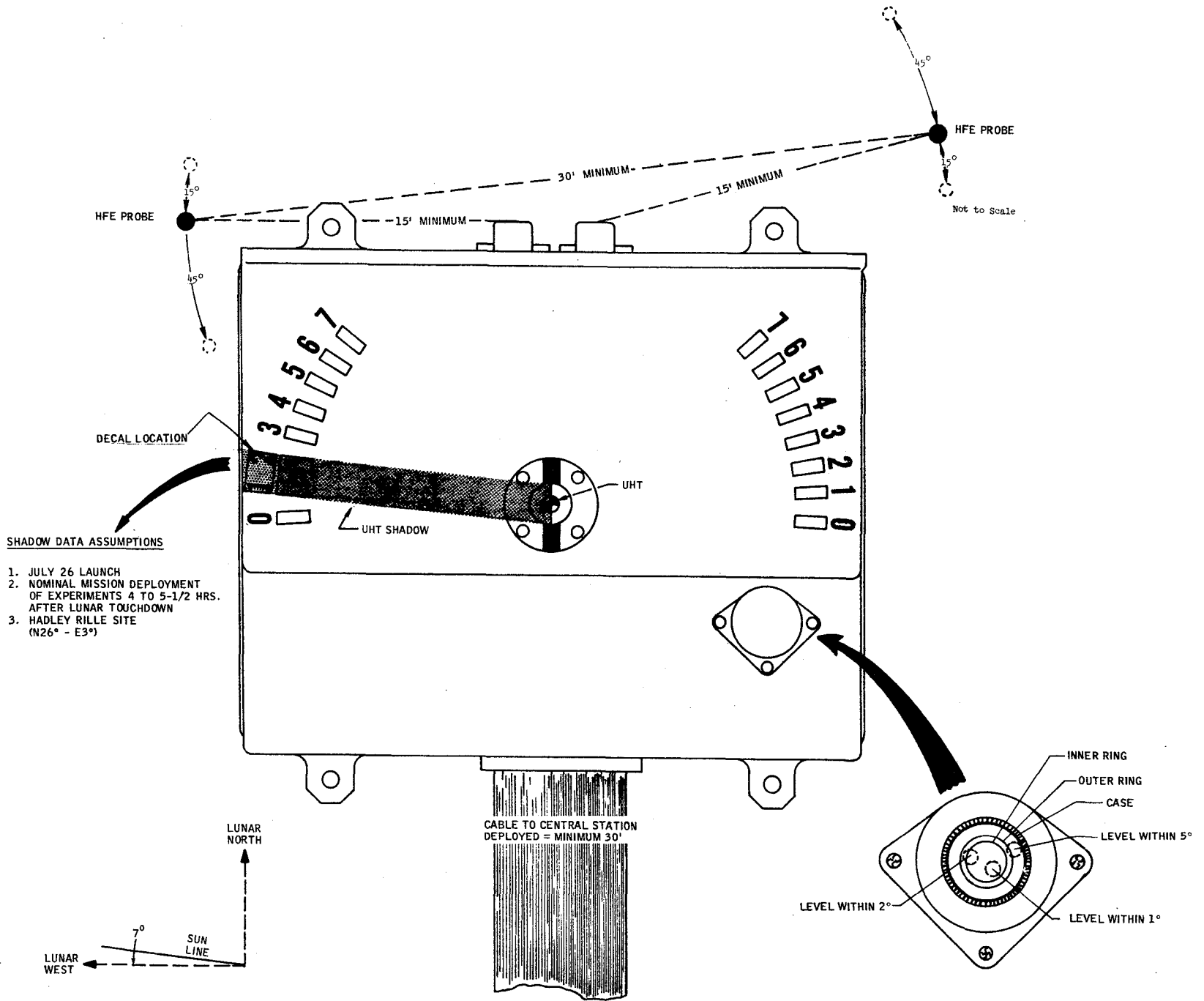

HEAT FLOW EXPERIMENT LEVELING AND ALIGNMENT

LRRR DEPLOYMENT CONSTRAINTS

PARAMETER	CONSTRAINTS
LRRR - LM Separation	Minimum mandatory distance is 300 to 500 feet due West of LM. A deployment distance of greater than 500 feet is requested to minimize dust fallout from LM ascent engine blast.
Leveling	Must be leveled by astronaut using bubble level within 5 degrees with respect to indicator. It should be noted that the optical performance of the reflector degrades as the off axis angle increases. It is therefore, necessary to aim the array as accurately as possible toward the center of the earth's libration position.
Elevation	Astronaut must deploy the leveling leg which sets the elevation angle. For Hadley Rille site, the elevation angle is 26.8 degrees to the horizontal.
Alignment	Astronaut will align LRRR using sun compass, then report azimuth alignment by noting where shadow cast by gnomon falls on the index marks. Index marks are set for specific landing site and deployment date.

# LASER RANGING RETRO-REFLECTOR (LR<sup>3</sup>) LEVELING AND ALIGNMENT

