



**erospace  
ystems Division**

*R. Miley*

EASEP SOLAR PANEL OCCULTATION

NO.	REV. NO.
EATM-59	A
PAGE <u>1</u>	OF <u>9</u>
DATE 11 March 1969	

Prepared by: *F. Wallack*  
F. Wallack

Approved by: *J. E. McGrath*  
J. E. McGrath



erospace  
ystems Division

EASEP SOLAR PANEL OCCULTATION

EATM-59 | A

PAGE 2 OF 9

DATE 11 March 1969

TABLE OF CONTENTS

		Page
1.0	INTRODUCTION	3
2.0	SUMMARY	3
3.0	DISCUSSION	3
4.0	RESULTS AND CONCLUSIONS	6



erospace  
ystems Division

## EASEP SOLAR PANEL OCCULTATION

EATM-59 | A

PAGE 3 OF       

DATE 11 March 1969

### 1.0 INTRODUCTION

This EATM describes the results of a detailed investigation and analysis performed to determine the effect upon the system during solar array occultation which can be encountered on the lunar surface during and after deployment by the astronaut or as a result of the terminator moving across the lunar surface.

### 2.0 SUMMARY

As a result of this analysis it is indicated that occultation of the lunar array during and after deployment must be limited.

*Brilliant*

The amount of occultation is largely determined by the geometry of the lunar sunlight angle of incidence, astronaut and solar array.

### 3.0 DISCUSSION

The solar array and P. C. U. were analyzed to determine the effect of solar panel occultation during lunar sunlight angles of incidence from zero (0) to one hundred eighty (180) degrees. Short and long term transients are also covered.

The solar array power output capability is considered during three periods, these are, three panels exposed to lunar sunlight at angles of incidence from zero (0) to sixty (60) degrees, six panels from sixty (60) to one hundred five (105) degrees and three panels from one hundred five (105) to one hundred eighty (180) degrees.

The P. C. U. regulation limits are compared to input power variance, time constants of transient inputs and switchover levels.

#### 3.1 The following tabulation indicates the solar array nominal output and distribution at lunar sunlight angles of incidence.

Sunlight Angle of Incidence to Solar Array	Three Panel "A" Power Output in Watts	Three Panel "B" Power Output in Watts	Solar Array Total Power Output in Watts
0 Degrees	37.0	0.0	37.0
15 "	41.5	0.0	41.5
30 "	43.0	0.0	43.0
45 "	41.0	0.0	41.0
60 "	37.0	0.0	37.0
75 "	28.0	10.0	38.0
90 "	20.5	20.5	41.0
105 "	10.0	28.0	38.0
120 "	0.0	37.0	37.0
135 "	0.0	41.0	41.0
150 "	0.0	43.0	43.0
165 "	0.0	41.5	41.5
180 "	0.0	37.0	37.0

3.2 The following table and graph reflect the solar array occultation limits in order to maintain satisfactory EASEP operation:



Sunlight Angle  
of Incidence

Maximum Permissible Percent Occultation

Three Panel "A"

Three Panel "B"

	0 Degrees	33.00	100.00	
	15 "	40.25	↑ ↓	
	30 "	43.00		
	45 "	39.50		
A	75 "	8.44		100.00
B	75 "	34.73	00.00	
C	90 "	39.50	00.00	
D	90 "	00.00	39.50	
E	105 "	00.00	34.73	
F	105 "	100.00	8.44	
	120 "	↑ ↓	33.00	
	135 "		39.50	
	150 "		43.00	
	165 "		40.24	
	180 "		100.00	33.00

NOTE 1

- (a) Occultation conditions may exist for: - A or B at 75°, C or D at 90°, E or F at 105°
- (b) Occultation of both sides of the array is highly unlikely in a lunar environment with one astronaut, these data are included for continuity



**erospace  
systems Division**

EASEP SOLAR PANEL OCCULTATION

EATM-59

A

PAGE 6 OF       

DATE March 11, 1969

3.3 The P. C. U. input power requirements and transient sensitivities are as follows:

3.3.1 Minimum input power to maintain regulation is 24.8 watts.

3.3.2 When the input power is reduced to 23.8 watts, the P. S. E. is rippled off to the standby mode.

3.3.3 Switchover from P. C. U. #1 to P. C. U. #2 will occur in the event that the power input decreases to 19.8 watts for 300 milliseconds or more.

3.3.4 In the event that the power input decreases to 19.8 watts, for less than 290.00 milliseconds switchover will not occur.

4.0 RESULTS AND CONCLUSIONS

4.1 An increase in occultation of four (4) percent in addition to the limits shown by Figure I, or paragraph 3.2, will cause the P. S. E. to be "rippled off" to a standby mode.

4.2 An occultation of twenty (24) percent in addition to the limits shown by Figure I, or paragraph 3.2 and maintained for a period of 300 milliseconds or more will cause P. C. U. No. 1 to switchover to P. C. U. No. 2. See Figure II, B.

4.3 On occultation of twenty-four (24) percent in addition to the limits shown by Figure I, or paragraph 3.2 and maintained for a period of 290 milliseconds or less will not cause P. C. U. switchover. See Figure II, A.

4.4 The response time of the solar panel is not added to periods of occultation due to its rapid decay and recovery time, i. e. the solar panel output power decreases to thirty (30) percent of maximum, ten (10) microseconds after 100% instantaneous occultation.

4.5 Transient occultation of the solar array for durations of less than 290.00 milliseconds and within the magnitude and distribution limits described in paragraphs 3.2 and 3.3 will not effect system operation. See Figure II, A.

4.6 Central Station Verification tests conducted at BxA revealed that below 24.8 watts input to the P. C. U., the voltage regulator becomes marginal and at 19.8 watts the dwell time becomes a factor in switching from P. C. U. No. 1 to P. C. U. No. 2. The rate of change from 24.8 to 19.8 watts or conversely from 19.8 to 24.8 watts is not significant.



erospace  
systems Division

EASEP SOLAR PANEL OCCULTATION

4.7 Occultation of the solar array in excess of the limits described in paragraph 3.2 can result in the P. C. U. switchover and the resultant loss of redundancy, decreasing the system reliability. The P. C. U. may be restored to the initial mode (i. e. switchover of P. C. U. No. 2 to P. C. U. No. 1) via earth command. This mode places the EASEP UPLINK system reliability in series with the P. C. U. and P. C. U. switchover system, decreasing the overall system reliability. The decrease in reliability from the initial mode to the switched-over mode is shown by the following block diagram.

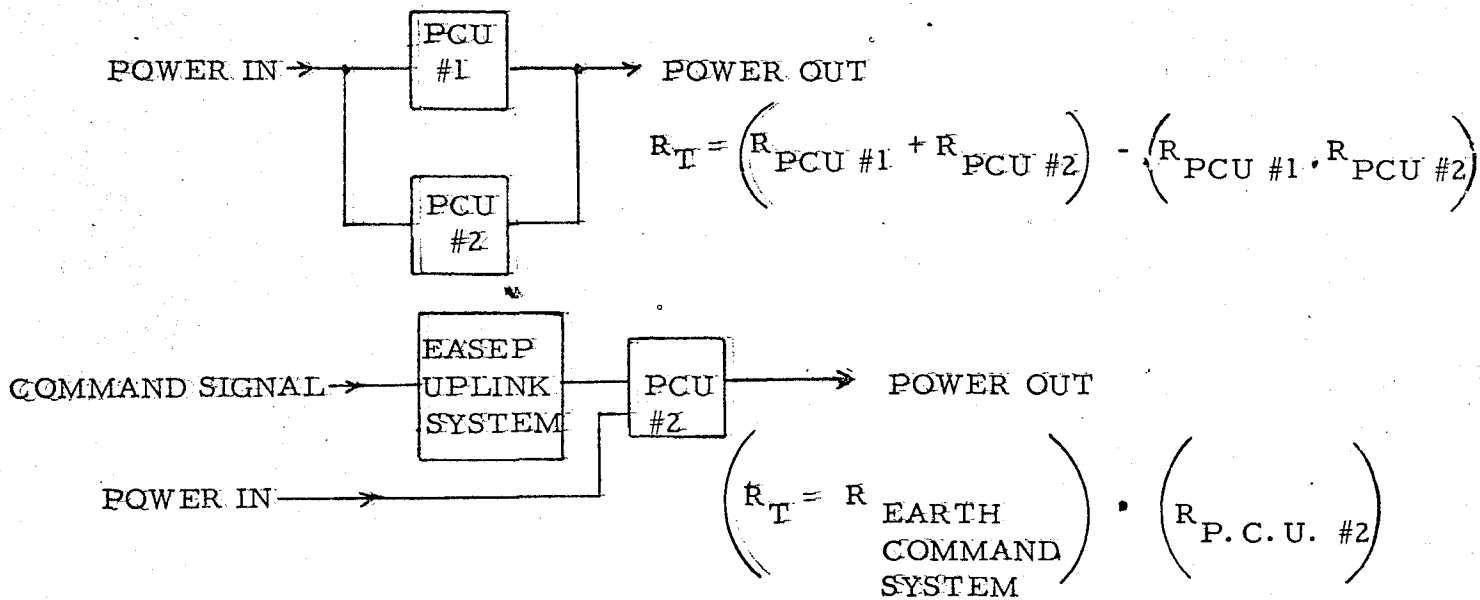

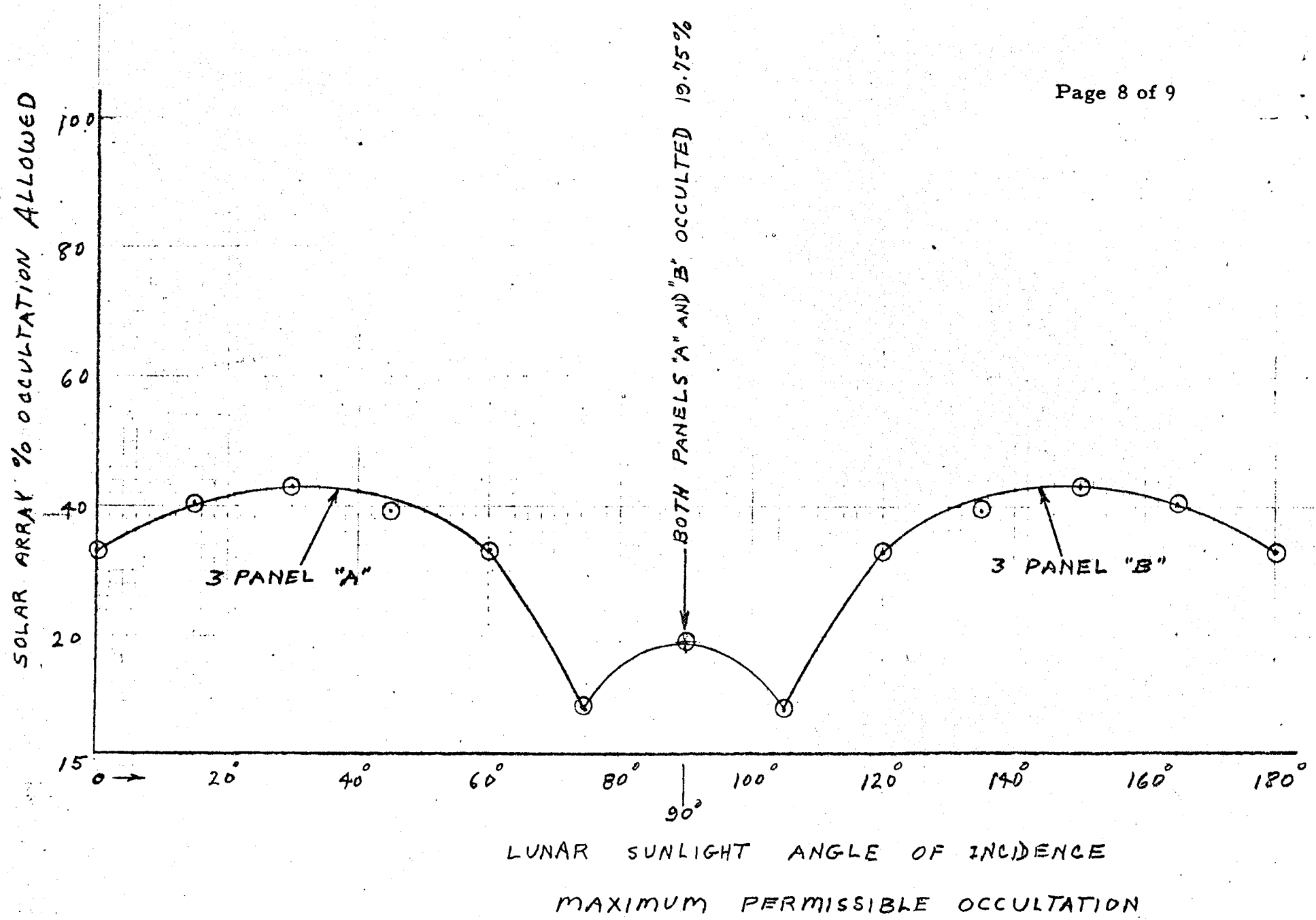

FIGURE I



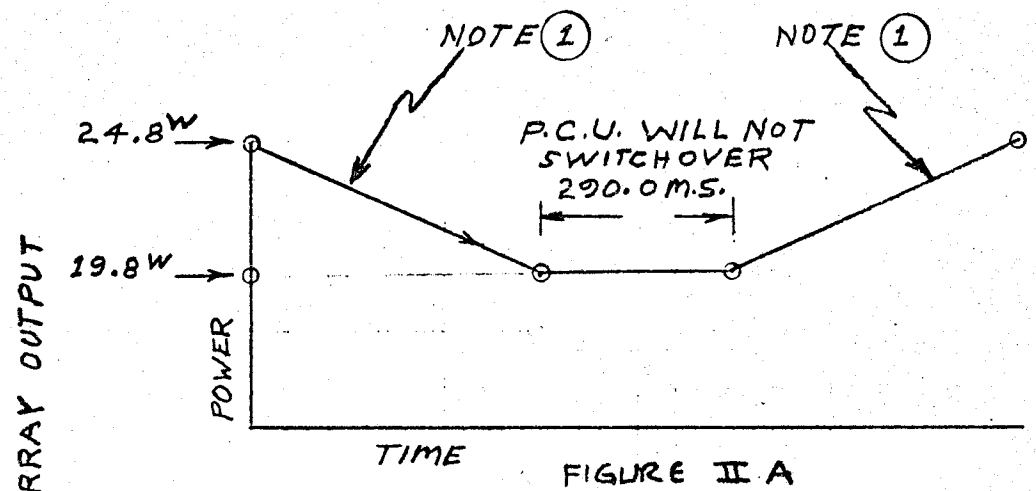

FIGURE II A

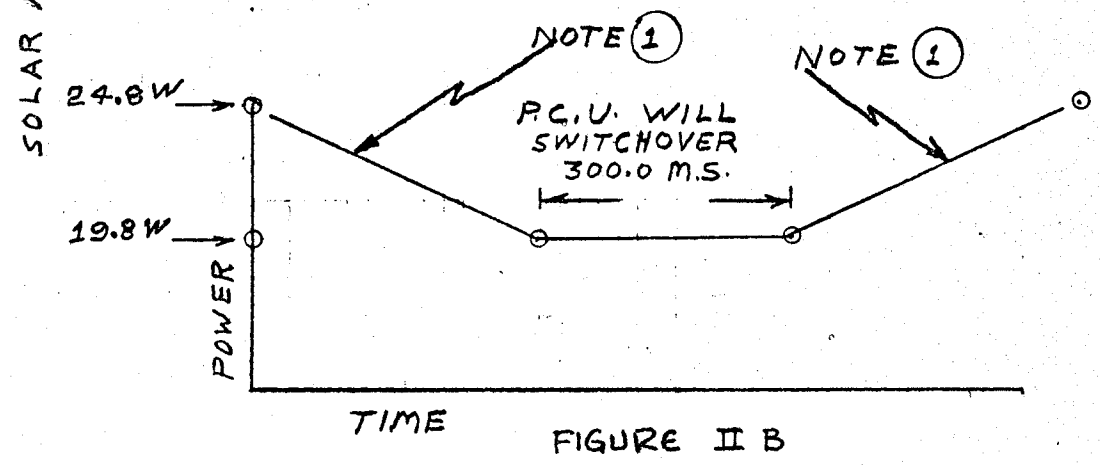

FIGURE II B

NOTE (1)  
SLOPE IS NOT SIGNIFICANT

FIGURE II  
SOLAR ARRAY TRANSIENT OCCULTATION LIMITS