



**Aerospace
Systems Division**

R. BRADFORD
BoydBoets

ALSEP FASTENER STUDIES

NO.	REV. NO.
ATM718	
PAGE <u>1</u>	OF <u>14</u>
DATE 6 December '67	

This unscheduled ATM has been written to summarize and document all the design and testing effort conducted on the ALSEP fastener to date.

Prepared by: W. Hamill
Warren Hamill

Approved by: Manfred Katz
Manfred Katz

Approved by: Thomas Fenske
Thomas Fenske



**Aerospace
Systems Division**

NO.	REV. NO.
ATM718	
PAGE <u>2</u>	OF <u>14</u>
DATE 6 December '67	

ALSEP FASTENER STUDIES

- 1.0 Summary
- 2.0 Fastener Requirements
 - 2.1 Original Fastener Requirements
 - 2.2 Modified Fastener Requirements
- 3.0 Calfax Live Lock
 - 3.1 Fastener Research
 - 3.2 Evaluation Tests - Calfax Live-Lock
- 4.0 Calfax Replacement Study
- 5.0 Evaluation Tests - Calfax Replacements
 - 5.1 ALSEP Compartment #1 Fastener Vibration Test
 - 5.2 Dynamic Load - Tensol Lock and Boydbolt Test
 - 5.3 Static Test - Tensol Lock Test
- 6.0 Conclusions and Recommendations
- 7.0 References



**Aerospace
Systems Division**

ALSEP FASTENER STUDIES

NO.	REV. NO.
ATM718	
PAGE <u>3</u>	OF <u>14</u>
DATE 6 December '67	

1.0 SUMMARY

The Calfax Live Lock fastener was selected for the original design since it met all the requirements set forth for the ALSEP fastener.

After the astronaut review of the original hardware it was stated that the total time for deployment was excessive. Bendix was directed to design a fastener, or fastening system, which would reduce the time required for unfastening.

Bendix reviewed many fastening schemes and selected promising candidates for further study and test. All fastening methods, other than the screw type, failed because the release force exceeded the capability of the astronaut while maintaining minimum structural integrity parameters.

The current recommendation is to use a Boydbolt, a 75° turn-to-release fastener, using a combination experiment handling and tie down release tool for unfastening. This recommendation meets the basic astronaut requirements, and satisfies all the structural specifications.

2.0 FASTENER REQUIREMENTS

The fastener requirements were established twice; once for the original ALSEP fastener and once for the directed modified fastener. Sections 2.1 and 2.2 outline these specific requirements.

2.1 Original Fastener Requirements

Bendix established the original fastener requirements from structural, human factors, and system engineering inputs. The original fastener criteria were as follows:

- 1) Physical properties high enough to satisfy the LM environmental loads; static and dynamic. (900 lbs. minimum tensile strength).
- 2) Capable of being quickly released with little effort, i.e., 17 inch-lbs on a 1 1/2" diameter handle.



**Aerospace
Systems Division**

ALSEP FASTENER STUDIES	NO.	REV. NO.
	ATM718	
	PAGE <u>4</u>	OF <u>14</u>
DATE 6 December '67		

- 3) Quantity of fasteners minimized.
- 4) No "hang-up" after initial release or unfastening.
- 5) Cold welding eliminated.
- 6) Simple and convenient astronaut release tool interface.
- 7) Commonality throughout the ALSEP system.
- 8) No pyrotechnic devices are permitted.
- 9) Minimum weight.
- 10) Use materials which are non-magnetic.

From these requirements the Calfax Live Lock fastener was selected for the original ALSEP design (see Section 3.0).

2.2 Modified Fastener Requirements

After the crew had an opportunity to evaluate the Calfax Live Lock on a crew engineering mock-up, a number of objections were submitted. These objections resulted in a revised set of requirements with direction from MSC to replace the Calfax Live Lock fastener. The specific objectives were as follows:

- 1) Reduce the time and effort required to deploy ALSEP. The suggested method of approach was to reduce the quantity of fasteners and to develop a non-twist type fastener.
- 2) Positive indication that the release mechanism has been actuated.
- 3) The possibility of re-engagement or "hang-up" after unfastening must be eliminated.
- 4) The impact on the present ALSEP design will be held to a minimum. (1/4 inch limit for the fastener diameter).



**Aerospace
Systems Division**

ALSEP FASTENER STUDIES

NO.	REV. NO.
ATM718	
PAGE 5	OF 14
DATE	6 December '67

Section 4.0 covers the study and testing conducted to satisfy these requirements.

3.0 CALFAX LIVE LOCK

The Calfax Live Lock fastener (see Figures 1, 2, 3) was selected for the original design after extensive investigation. This investigation took the form of contacting specific fastener companies and agencies throughout the country.

The specific features of the Calfax Live Lock fastener which satisfy the requirements listed in Section 2.1 are as follows:

- 1) Mechanical Properties for Calfax Live Lock, 1/4 diameter
 - Rated tension --- 900 lbs.
 - Ultimate tension load --- 1200 lbs.
 - Rated shear load --- 1730 lbs.
 - Ultimate shear load --- 3000 lbs.
 - Sheet separation --- not to exceed .015 inch at rated tensile load
 - Locking torque --- 30 inch-lbs.
- 2) 3/4 to 1 turn to release fastener.
- 3) Incorporation of a retaining ring washer to prevent remote possibility of the stud tending to refasten.
- 4) Solid film lubricant (Electrofilm 2306) to prevent cold welding and provide a reliable lubrication system.
- 5) A total quantity of 19 fasteners were required to provide adequate tie down for the sunshield (this was proven minimum per test TR 2267, reference No. 13)
- 6) Dynamic integrity verified by Lockheed Missiles and Space Company's Test Report No. A5184-2, Litton Data Systems Test MJO 2907-12 and meets the requirements specified in MIL-F-22978A (references 1, 2, 3, 4)

3.1 Fasteners Research

Table 1 presents the fastener companies and the specific type fastener which were considered for the original ALSEP design.



**Aerospace
Systems Division**

NO. ATM718	REV. NO.
PAGE <u>6</u> OF <u>14</u>	
DATE 6 December '67	

ALSEP FASTENER STUDIES

Table 1

Fastener Sources Researched

<u>Company</u>	<u>Person Contacted</u>	<u>Type of Fastener</u>
Grumman Aircraft Bethpage, Long Island	Robert Caughlin Jack LaRussa	General quick release and specifically Calfax's Live Lock
Standard Pressed Steel Santa Ana, California	J. Owens	Milson structural panel fastener
"APIC" Apollo Parts Information Center, Huntsville, Ala.	Glen Lindsey Earl Pugh J. Rizzardi	General quick release astronaut approved fasteners. Fastener test reports
Simmons Fasteners Albany, New York	William C. Kraft	Lock stud, Link lock
Camloc Fastener Corp. Paramus, New Jersey	J. Frederic Dreher	1/4 turn fasteners, Stressed panel fastener
Cinch Monadnock City of Industry, Calif.	Applications Engineer	Airlock (1/4 turn)
Deutsch Fastener Corp. Los Angeles, Calif. Dayton, Ohio	E. O. Baumgarten Dick Lowry	Quarter loc stud, Zip loc, Turn-loc, Press-loc fastener
South Co. Fasteners		Lion 1/4 turn
Dzus Fasteners West Islip, New York		Universal Fastener, Standard 1/4 turn, Panel Fastener
Spiron, Inc.		High strength quick release
Timber-Top, Inc. Freeport, New York	John M. Sadler	Mini-synclamps quick release
Calfax, Inc. Torance, Calif.	Frank Cosenza	Live lock, Boydbolt,

3.2 Evaluation Tests - Calfax Live Lock

To prove the design integrity of the Calfax Live Lock fastener a number of tests were conducted by Bendix to expose any problems which might exist. The first three tests were pre Proto #1.

1) Calfax Fastener Vibration Test

Test Requirements - Memo 9712-190 (Reference No. 5)
Test Report - TR 1980 (Reference No. 7)
Date Conducted - 12/19/66

Summary - The dummy Passive Seismic experiment (20 lbs.) was subjected to the existing qualification dynamic levels. The four Calfax Live Lock fasteners tested passed with no unfastening or unacceptable release torques.

2) Calfax Fastener Thermal Vacuum Test

Test Requirements - Memo 9712-190 (Reference No. 5)
Test Report - TR 1942 (Reference No. 6)
Date Conducted - 1/3/67

Summary - one mounted fastener was subjected to 1.0×10^{-8} torr and 300°F for a period of 48 hours and 120 hours. No cold welding occurred and all release torques were under 18 in-lbs.

3) Calfax Fastener - Cold Environment

Test Requirements - Memo 9712-190 (Reference No. 5)
Test Report - TR 2076 (Reference No. 8)
Date Conducted - 2/1/67

Summary - One mounted fastener was subjected to low temperatures and its release torque recorded. Temperatures of -60°F can be experienced by the fastener and still be released with less than 16 in-lbs. torque.

4) Proto #1 Test

Test Requirements - Memo 9712-181 (Reference No. 9)
Memo 9712-332 (Reference No. 10)
Memo 9712-385 (Reference No. 11)



**Aerospace
Systems Division**

ALSEP FASTENER STUDIES	NO. ATM718	REV. NO.
	PAGE <u>8</u> OF <u>14</u>	
	DATE 6 December '67	

Test Report - TR 2152
Date Conducted - 5/19/67

The first time the Calfax Live-Lock fastener was tested in the ALSEP system was the Proto #1 structure for Compartment #1.

The test article consisted of the primary structure, thermal plate, sunshield, dummy experiments and dummy electronic modules. The Calfax Live-Lock fastener was used to retain all experiments and sunshield tie downs. The vibration environment was to the ATR-16 levels. These levels were more severe than the levels previously used (i.e., sinusoidal inputs at 50 cps required 6.0 g's for ATR-16 and previously required 3.5 g's).

Loosening of the Calfax Live-Lock fastener occurred on the experiments and sunshield during the sine sweep only. At no time did a fastener release completely, however, an improvement in the locking feature had to be made. All efforts in connection with the unloosening problem on the Calfax Live-Lock were terminated when MSC directed Bendix to study and implement a non-twist type fastener to replace the Calfax Live-Lock.

4.0 CALFAX REPLACEMENT STUDY

To satisfy the requirements set forth in Section 2.2, an investigation into non-twist type fasteners was conducted. Table 2 presents the non-twist fasteners which were considered for the Calfax Live-Lock replacement.

In addition to the sources in the fastener industry, Bendix Aerospace investigated designs of various fastening methods listed in Table 3.

A common criteria of all the fastening systems was a 330 lbs. minimum pretension. This minimum requirement was established by testing on the Proto #1 model of Compartment #1 (see Section 5.1). Along with this pretension requirement there are astronaut constraints which limit the release force capability as follows:

- 1) Maximum downward force - 20 lbs.
- 2) Maximum upward force - 5 lbs. (ALSEP lifts off lunar surface)
- 3) Maximum sideward force - 4 lbs. (assume $\mu = .4$)



**Aerospace
Systems Division**

ALSEP FASTENER STUDIES

NO.	REV. NO.
ATM718	
PAGE 9	OF 14
DATE	6 December '67

After preliminary investigation of the non-twist type fasteners, both general industry and Bendix designs, the Tensol Lock (push-to-release, see Figure 5) was selected as the basic design to develop and test further.

Figure 4 compares the preload vs. release force required for each individual fastener evaluated in the study.

Although the Tensol Lock fasteners are not commonly made in the 1/4" diameter size, preliminary tests run by Norco, Inc. (manufacturer of Tensol Lock) and their engineering judgement indicated that the Tensol Lock would operate satisfactorily in the 1/4" size.

In addition to the non-twist type fastener a Boydbolt (twist type) was considered as a fastening back up method. The Boydbolt (see Figure 6) which basically is a fast lead screw with a pip pin locking feature looks very promising on paper in addition to the limited testing conducted on it. The basic or standard design has been modified to reflect certain features which satisfy the present ALSEP design criteria and is called a Boydbolt-special (see Figure 7).

The specific features of the Boydbolt-special are as follows:

- 1) 75° twist to release
- 2) Ball lock locking feature which provides a positive mechanical constraint against dynamic unloosening.
- 3) Locking spline in the unfastened position to prevent possible refastening.
- 4) A spring incorporated into the fastener head to assist fastener extraction and insure positive release.
- 5) Dead ending the threads such that a positive stop is provided when 75° has been turned.
- 6) A preloading nut to provide the necessary tension required and also allow slight variations in grip lengths.



**Aerospace
Systems Division**

ALSEP FASTENER STUDIES	NO. ATM718	REV. NO.
	PAGE <u>10</u> OF <u>14</u>	
	DATE 6 December '67	

- 7) Multisided socket head on the tie down release tool engagement interface.
- 8) Stepped down bolt shank to ensure that the balls in the locking mechanism do not protrude beyond the 1/4 inch shank.

The special version of the Boydbolt is in the development stage at this time, therefore evaluation testing on the specific flight design has not been done.

Table 2

Non Twist Type

Company	Person Contacted	Type of Fastener
Avdel, Inc. Burbank, Calif.	Duran	Ball-lok pins
Adjustable Bushing Corp. North Hollywood, Calif.	Ken Pitzer	Expando grip
Space Lok, Inc. Burbank, Calif.	R. Maddox	Quick release pip-pins, Test results in tension
Norco Georgetown, Conn.	Heath McDowell Ray Metz	Tensol lock, Stud lock, Cuplex, Interlock

Table 3

Bendix Investigated Designs

- 1) Manual break-away bolts
- 2) Keyhole or elongated slide mechanisms
- 3) Pneumatic system
- 4) Ganged slide latch
- 5) Ganged push-pull mechanisms
- 6) Split nut on shouldered bolt



**Aerospace
Systems Division**

ALSEP FASTENER STUDIES

NO.	REV. NO.
ATM718	
PAGE 11	OF 14
DATE 6 December '67	

5.0 EVALUATION TESTS - CALFAX REPLACEMENTS

The objectives to be accomplished through testing were as follows:

- 1) Establish the minimum pretension and the minimum number of fasteners required to tie down the sunshield to the primary structure.
- 2) Evaluate the performance (dynamic and static) of the prototype Tensol-Lock fasteners, 1/4" diameter, supplied by Norco, Inc.
- 3) Evaluate the dynamic performance of the Boydbolt fastener supplied by Tridair Industries.

Three separate tests were conducted to achieve these objectives, namely, the ALSEP Compartment #1 Fastener Vibration Test, Dynamic Load-Tensol Lock and Boydbolt test, and Static Load-Tensol Lock test.

5.1 ALSEP Compartment #1 Fastener Vibration Test

Test Requirements - Memo 9712-455 (Reference 13)
Test Report - TR 2267 and Memo 9712-566 (Reference 14, 15)
Date Conducted - 9/13/67

Summary - ALSEP Proto #1 model of Compartment #1 was subjected to a series of qualification level (LTA-3) sine vibration tests.

The quantity (19 to 11) and preload (0 to 500 lbs.) of the sunshield fasteners were varied with each test and the resulting deflection and g load recorded.

A 330 lbs. pretension combined with the original quantity of sunshield fasteners (19) is the minimum recommended configuration. All other combinations resulted in excessive sunshield deflections.

5.2 Dynamic Load - Tensol Lock and Boydbolt Test

Test Requirements - Memo 9712-521 (Reference 16)
Date Conducted - 10/6/67



**Aerospace
Systems Division**

ALSEP FASTENER STUDIES

NO.	ATM718	REV. NO.
PAGE <u>13</u> OF <u>14</u>		
DATE 6 December '67		

- 3) The Tensol Lock fastener tested did not show repeatability in performance. Sometime the fasteners would work as desired, while at other times the release force would be extremely high. The main cause of its erratic performance is mainly due to the smallness in size (1/4" diameter). The 1/4" diameter Tensol Pin design is borderline and should not be considered further.

- 4) The Boydbolt successfully passed the LTA-3 DR qualification levels on the LSM Proto #1 structure. The fastener satisfies the ALSEP design criteria and is adaptable into a 75° turn to release version.

This design is recommended as the basic fastening method for ALSEP.

- 5) As a future fastening method the area of pyrotechnics should be reconsidered. These devices lend themselves to the ALSEP design because of the high quantity of fasteners needed.

7.0 REFERENCES

<u>Ref. No.</u>	<u>Date</u>	<u>Identification No.</u>	<u>Title of Document</u>
1	September '66	Report MJO 2907-12	Litton Data Systems Calfax Panel Fasteners
2	September '66	Report A 5184-2	Lockheed's Qualification Tests of "Calfax Type" High Strength Rotary Panel Fasteners
3	September '66	Report 1415138	General Specifications for Panel Fasteners, Rotary, Quick Operating, High Strength
4	September '66	MIL-F-22978A	MIL SPEC. Fastener, Rotary, Quick Operating, High Strength
5	October '66	Memo 9712-190	Test Requirements - Calfax Fastener



**Aerospace
Systems Division**

ALSEP FASTENER STUDIES	NO. ATM718	REV. NO.
	PAGE 14	OF 14
	DATE 6 December '67	

<u>Ref. No.</u>	<u>Date</u>	<u>Identification No.</u>	<u>Title of Document</u>
6	January '67	TR 1942	Test Report - Calfax Thermal Vacuum Evaluation
7	February '67	Report TR 1980	Test Report - Calfax Vibration Evaluation
8	April '67	Report TR 2076	Test Report - Calfax Cold Environment Evaluation
9	October '66	Memo 9712-181	Test Requirements - Dynamic Test of ALSEP Compartment 1 Structural Assembly
10	March '67	Memo 9712-332	Test Requirements - Dynamic Test of ALSEP Compartment 1 Structural Assembly
11	May '67	Memo 9712-385	Test Requirements - ALSEP Proto #1 Compartment #1 Vibration Test
12	June '67	Report TR 2152	Test Report - ALSEP Compartment #1, Proto No. 1
13	August '67	Memo 9712-455	Test Requirement - ALSEP Compartment #1, Fastener Vibration Test
14	October '67	Report TR 2267	Test Report - ALSEP Compartment #1, (Prototype 1) Fasteners
15	October '67	Report 9712-556	Test Report - ALSEP Compartment #1 Fastener Vibration Test Results
16	October '67	Memo 9712-521	Test Requirements - Calfax Fastener Replacement
17	October '67	Report TR 2260	Test Report - Static Load Calfax Fastener Replacements

CA18018

B

8-32NC-3A, 4 LEAD TNEAD SCREEN

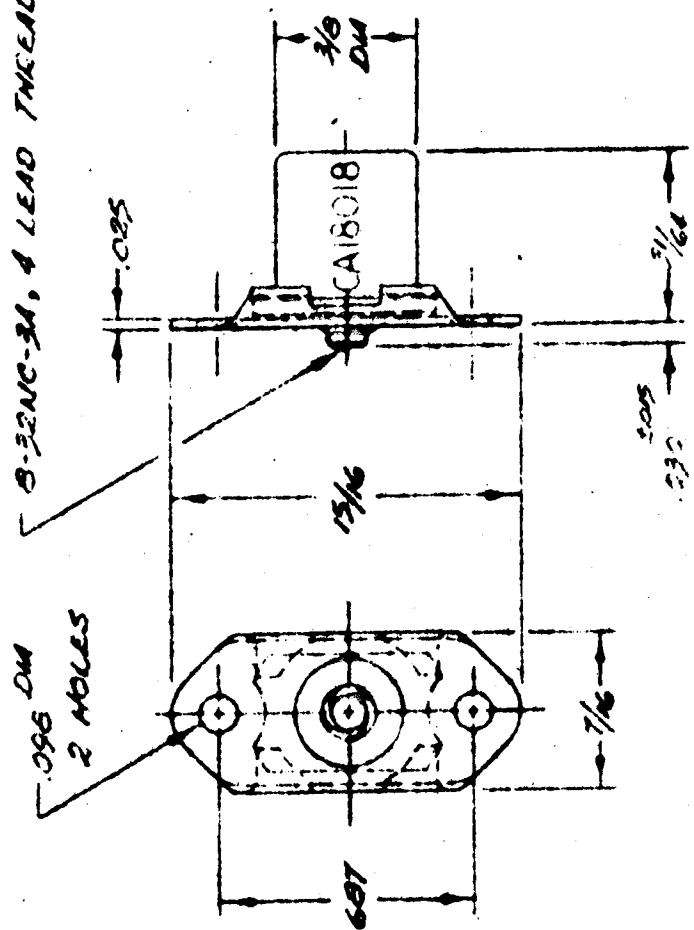

- NOTES:
1. TO BE USED WITH CA18007 STUD NUT & CA18025 RETAINING RING
 2. RECEPTACLE TOTAL FLOAT: .085 MM
 3. SCREEN & RETAINING COMPONENTS DRY FILM LUBED WITH ELECTROFILM #2906 FOR HIGH VACUUM APPLICATIONS
 4. SPRING PRESSURE ON BUTCHNET PLATES 0.5 LBS MM

FIG. 1

DATE	REV	CHANGE	BY	CHKD	APPV	DATE	REVISION
	A	ADDITIONAL DIMENSIONS TO DRAWING					
	B	REVISION 1: CHANGES TO CA18018 DRAWING 085 THE TITLE BLOCK					
UNLESS OTHERWISE SPECIFIED			MATERIAL OR NAME				
DIMENSIONS ON DIM			DRAWN BY				
DECIMALS 25 1 010			ENGINEERING				
FRACTIONS 1/8 1/16			APPROVED				
ANGLES 1 1/2			FINISH				
SCREEN: 140,000 PSI			HEAT TREAT				
.0127 LB/IN ²			SCALE				
SCREEN - 1-296 CRES			MATERIAL OR NAME				
HOUSING - 18 TYPE 304 STAINLESS CRES			SPECIFICATION				
AUG 5773			RECEPTACLE ASSY				
MIL-S-7720			LIVE LOCK • 3/4 TURN				
CALIFAX, Inc.			REVISION				
A MEMBER OF THE TAYLOR GROUP			DATE				
171 40-33-4204			DRAWN BY				
Phone 213-772-4311			ENGINEERING				
FAX 213-772-4311			APPROVED				
Pasadena Road 92270, California			FINISH				

CA18007-
SHT 1 OF 2

C

FIG. 2

Dash No.	Grip Weight		MT
	min	max	
1	1.51	1.813	1.85
2	1.562	1.864	1.907
3	1.593	1.876	1.958
4	1.626	1.887	2.009
5	1.656	1.898	2.060
6	1.687	1.909	2.111
7	1.718	1.920	2.162
8	1.750	1.932	2.213
9	1.781	1.943	2.264
10	1.812	1.954	2.315
11	1.843	1.965	2.366
12	1.875	1.976	2.417
13	1.906	1.987	2.468
14	1.937	1.998	2.519
15	1.968	2.009	2.570
16	1.999	2.020	2.621
17	2.030	2.031	2.672
18	2.061	2.042	2.723
19	2.092	2.053	2.774
20	2.123	2.064	2.825
21	2.154	2.075	2.876
22	2.185	2.086	2.927
23	2.216	2.097	2.978
24	2.247	2.108	3.029
25	2.278	2.119	3.080
26	2.309	2.130	3.131
27	2.340	2.141	3.182
28	2.371	2.152	3.233
29	2.402	2.163	3.284
30	2.433	2.174	3.335
31	2.464	2.185	3.386
32	2.495	2.196	3.437
33	2.526	2.207	3.488
34	2.557	2.218	3.539
35	2.588	2.229	3.590
36	2.619	2.240	3.641
37	2.650	2.251	3.692
38	2.681	2.262	3.743
39	2.712	2.273	3.794
40	2.743	2.284	3.845
41	2.774	2.295	3.896
42	2.805	2.306	3.947
43	2.836	2.317	4.000
44	2.867	2.328	4.051
45	2.898	2.339	4.102
46	2.929	2.350	4.153
47	2.960	2.361	4.204
48	2.991	2.372	4.255
49	3.022	2.383	4.306
50	3.053	2.394	4.357
51	3.084	2.405	4.408
52	3.115	2.416	4.459
53	3.146	2.427	4.510
54	3.177	2.438	4.561
55	3.208	2.449	4.612
56	3.239	2.460	4.663
57	3.270	2.471	4.714
58	3.301	2.482	4.765
59	3.332	2.493	4.816
60	3.363	2.504	4.867

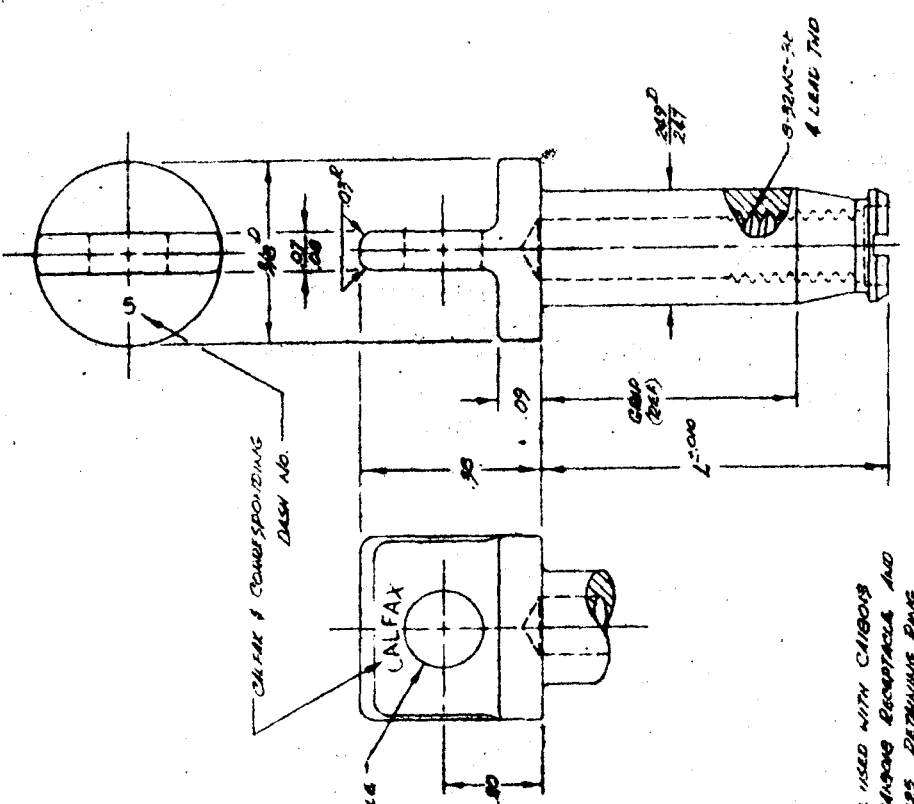

- NOTES:
1. TO BE USED WITH CALIFAX OR CALIFAX RECEPTACLE AND CALIFAX RETAINING RING
 2. TURNS REQUIRED TO TIGHTEN OR REMOVE STUD NUT:
3/4 AT MIN GRIP
1 AT MIN GRIP
 3. WEIGHTS SHOWN ARE CLOSE APPROXIMATIONS ONLY
 4. SEE SMT 2 FOR FASTENER MECHANICAL PROPERTIES AND INSTALLATION PROCEDURES

UNLESS OTHERWISE SPECIFIED
 DIMENSIONS IN INCHES
 FINISH
 UNLESS OTHERWISE SPECIFIED

10-5 TYPE 300 S.M.S. C245

MATERIAL OF NAME

STUD NUT-3/4 TURN
 --- SPADE HEAD ---

CA18007-
SHT 1 OF 2

Califax, Inc.
 2000 Corporate Blvd., Raleigh, North Carolina

FASTENER MECHANICAL PROPERTIES	
LOCKING TORQUE	30 INCH-LBS (MM)
UNLOCKING TORQUE	35 INCH-LBS (MM)
TORQUE-OUT	50 INCH-LBS (MM)
ULTIMATE SHEAR LOAD	2000 LBS (MM)
ULTIMATE TENSILE LOAD	1750 LBS (MM)
ULTIMATE TENSILE LOAD (BEST CONDITION)	1800 LBS (MM)
QUOTED TENSILE LOAD	900 LBS (MM)
SHEAR SEPARATION (BEST CONDITION)	NOT TO EXCEED 0.015 INCH
SHEAR PULL-UP	1/32 INCH (MM)
STUD PUSH-OUT	75 LBS (MM)
RECEPTACLE PUSH-OUT	75 LBS (MM)

NOTES:
1. RETAINING RING RECESS FOR CHIEFS RETAINING RING:
CBORE .900-.105 DIA X .030-.035 DEEP

2. STUD NUT HOLE SIZES:
A FOR PANEL A: .250-.265 DIA
B FOR PANEL B: .250-.265 DIA (MAY BE ADJUSTED UP TO .295 DIA TO CORRECT FOR MISALIGNMENT OF MATING STUDS & ACCEPTABLE.)

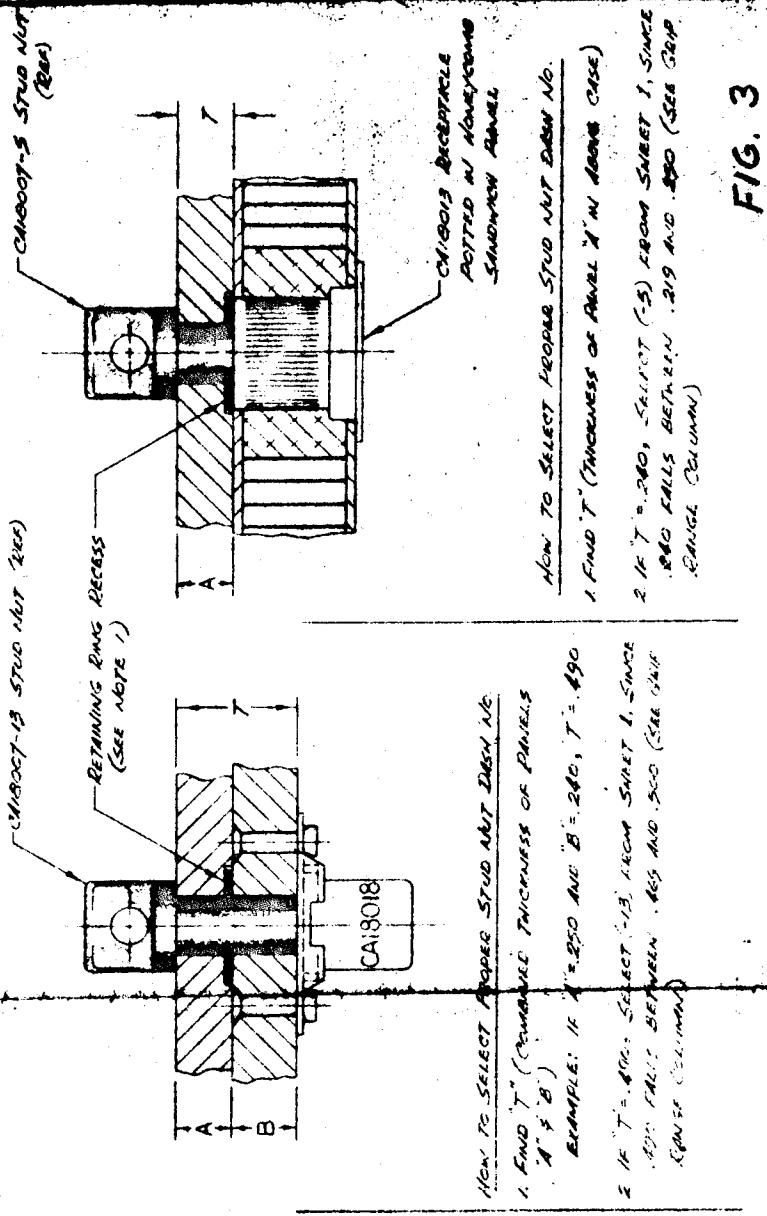

HOW TO SELECT PROPER STUD NUT DASH NO.
1. FIND "T" (REQUIRED THICKNESS OF PANELS "A" & "B")
EXAMPLE: IF A = .250 AND B = .240, T = .490
2. IF T = .490: SELECT "13" FROM SHEET 1. SINCE .490 FALLS BETWEEN .465 AND .500 (SEE RANGE COLUMN)

HOW TO SELECT PROPER STUD NUT DASH NO.
1. FIND "T" (THICKNESS OF PANEL "X" IN ABOVE CASE)
2. IF T = .280, SELECT (-5) FROM SHEET 1, SINCE .280 FALLS BETWEEN .219 AND .290 (SEE RANGE COLUMN)

FIG. 3

UNLESS OTHERWISE SPECIFIED	TOLERANCE ON DIM	FINISH	SCALE	DATE/TREAT	SCALE
	DECIMALS ± .010				
	FRACTIONS ± 1/64				
	ANGLES ± 1'				
MATERIAL OR NAME		INSTALLATION PROCEDURES		CA18007 - SHT 2 OF 2	
SPECIFICATION		1-19-52		1952 Copyright Mfg. Division, Lockheed Aircraft Corp.	
DRAWN BY		APPROVED		CALIFAX, INC. 1200 GARDEN CITY BLVD. GARDEN CITY, N.Y.	

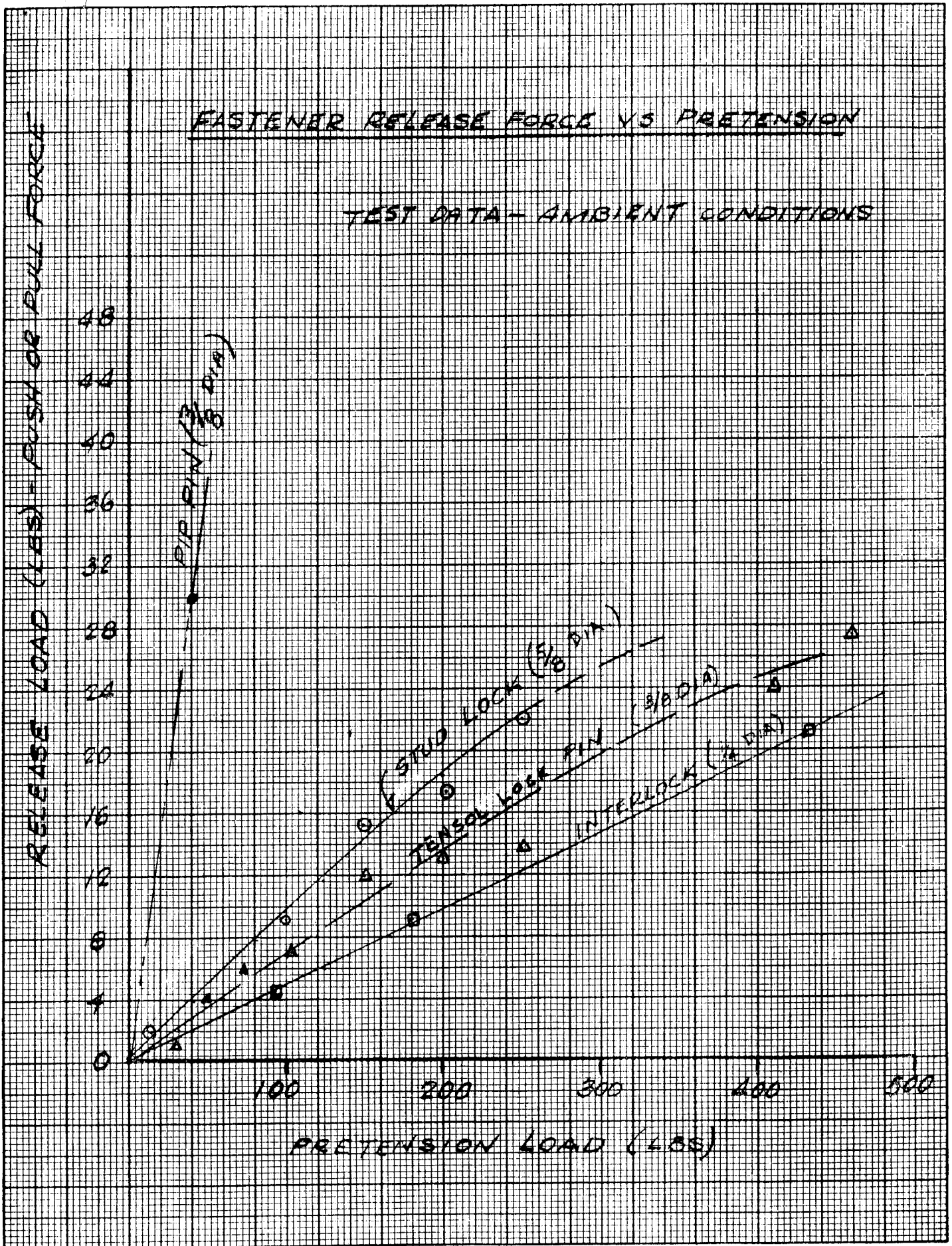

FIG. 4

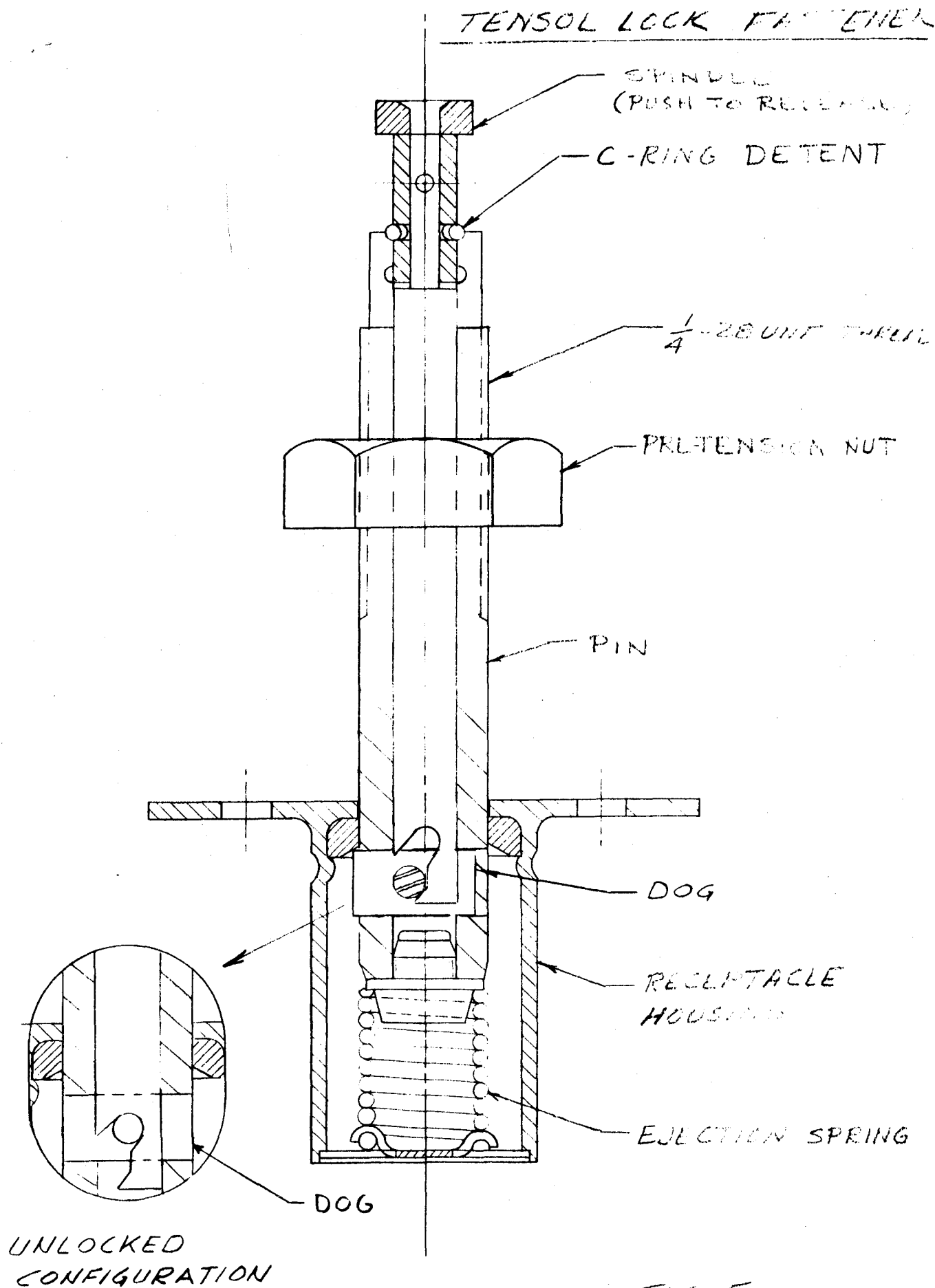

FIG. 5

BOYDBOLT FASTENER

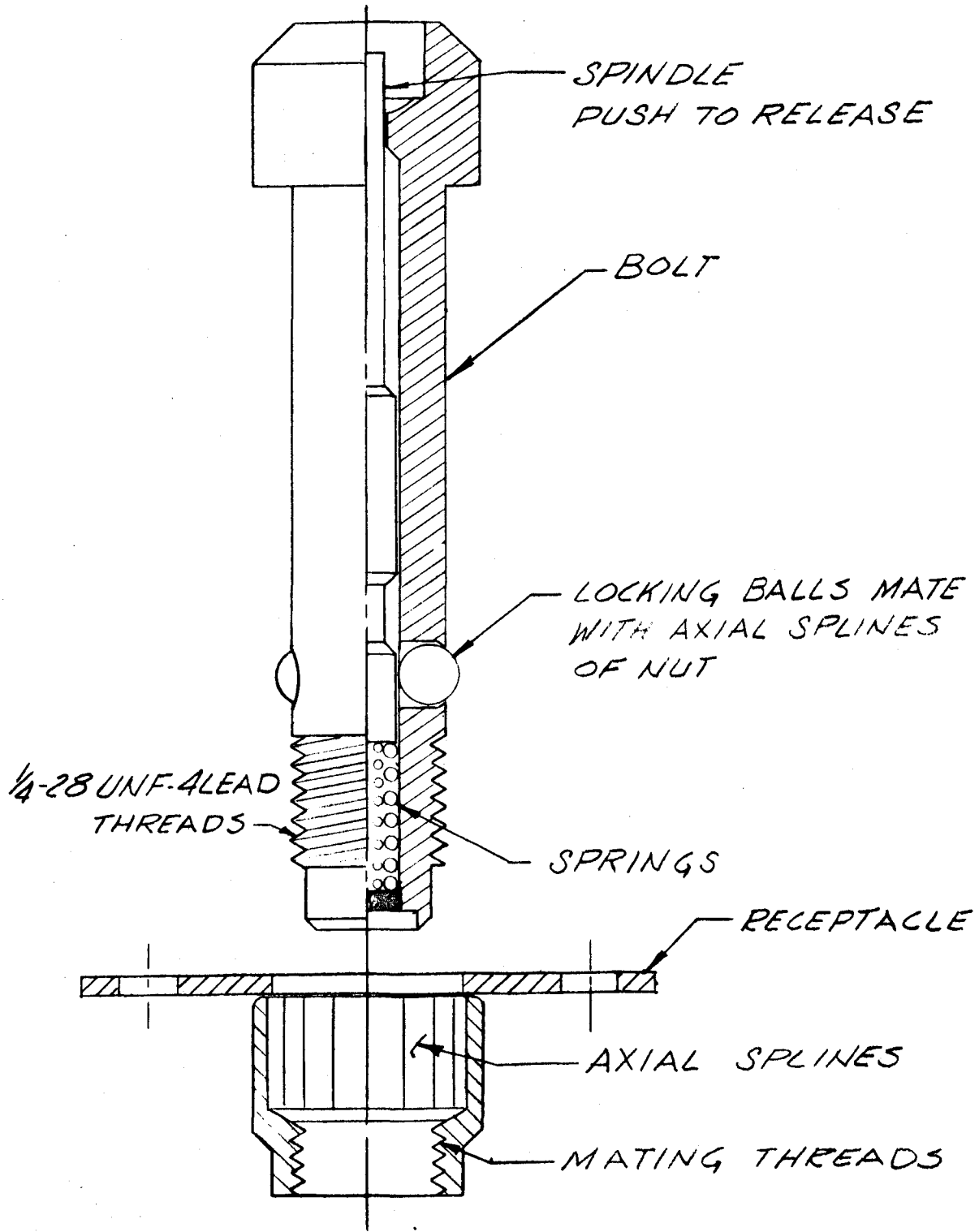
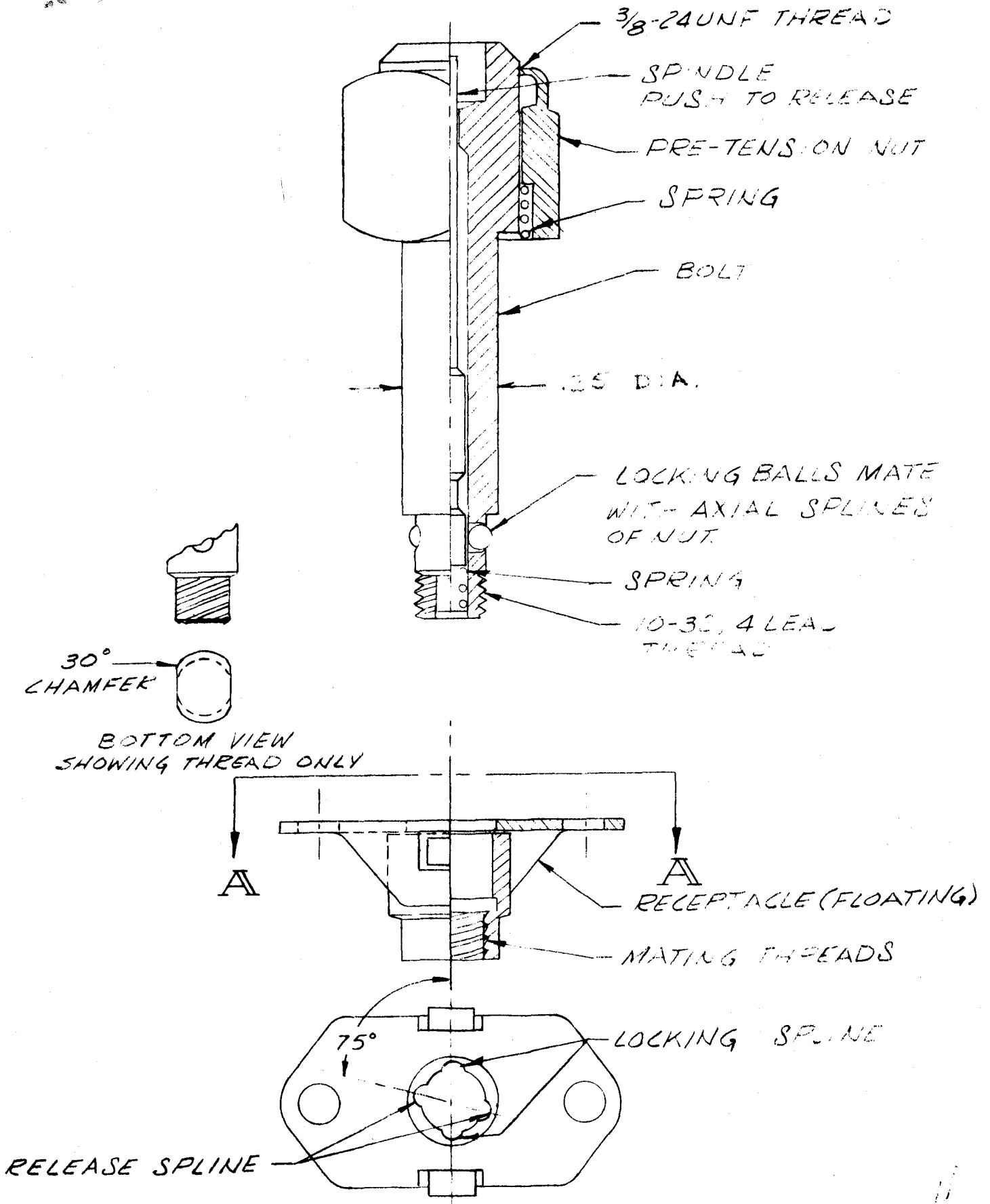

FIG. 6

BOYD BOLT - SPECIAL



SECTION AA

FIG. 7

2140 57
 37